

581365-8

Computer Organization II (Tietokoneen rakenne)



Teemu Kerola

University of Helsinki

Department of Computer Science

Fall 2003

Course Focus

- Understand basic computer system design from the user (human, OS, compiler) viewpoint as well as from the designer viewpoint.
- Understand how a simple hardware clock signal makes a computer to execute programs.

Peripheral topics

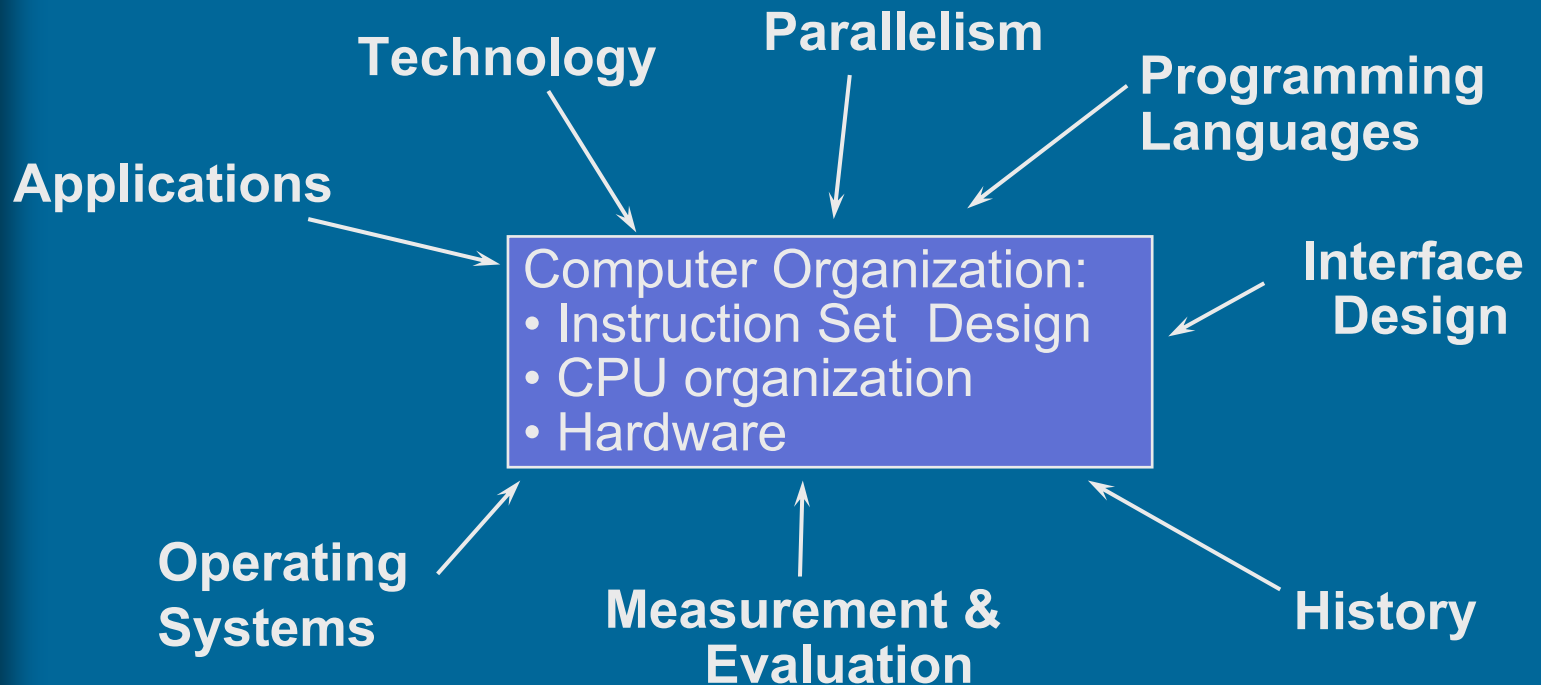

Related Courses

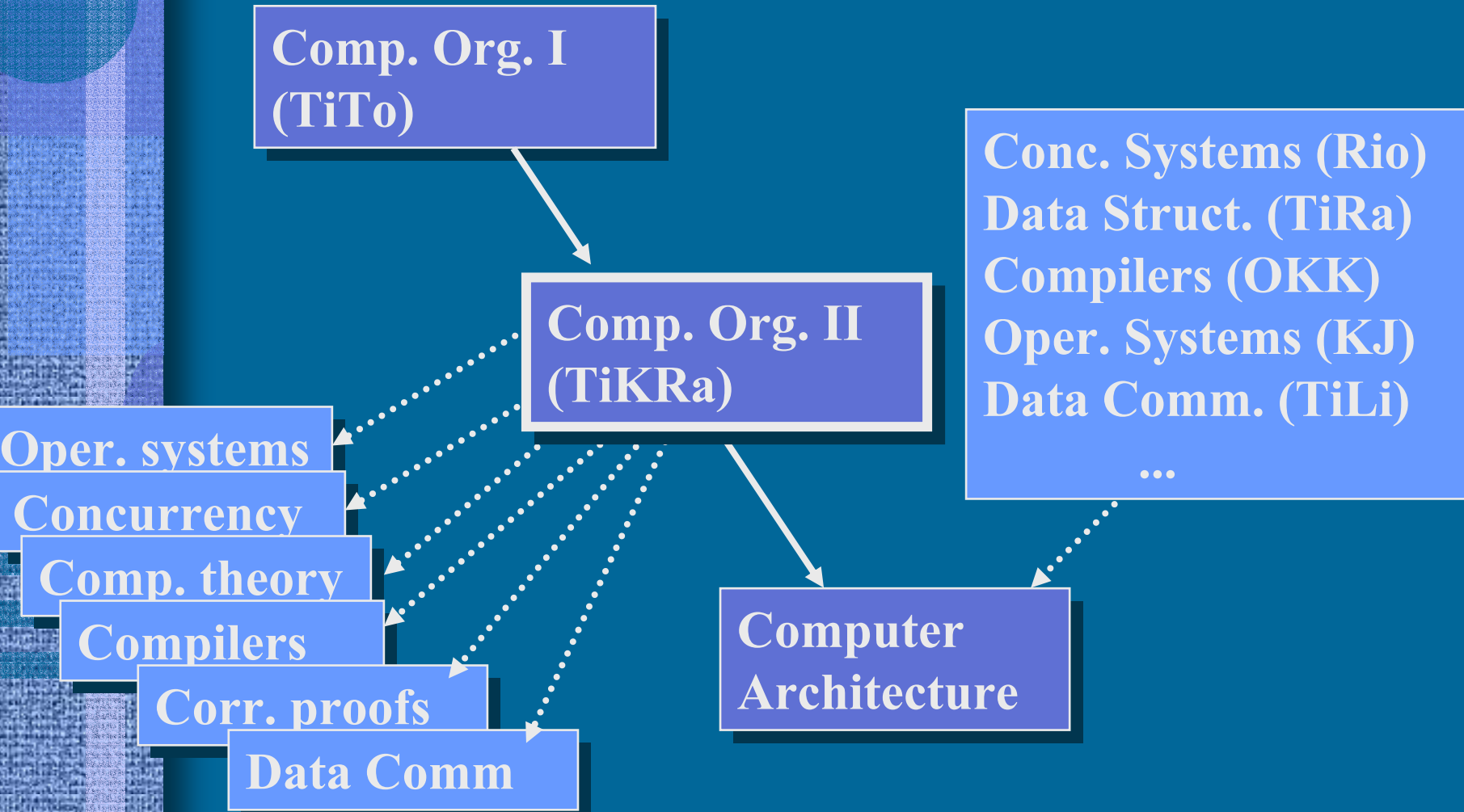

Notice

- These slides are made to support lectures and to be used with the text book.
- They do NOT include everything that is covered in the lectures.
- They are NOT a replacement for a text book.
- If you need a self-contained presentation, please use the text book.

Motto

- “It is not good exercise,
if you do not sweat”

(“Kunto ei nouse, jos ei tule hiki”)

Studying in an Ordinary 2 cr Lecture Course ⁽⁶⁾

- Lectures 4h / w
 - lecture notes in web, make copies in advance
 - learn basics in lecture
- Read same material from text book 6h / wk
 - little bit different approach
- Do homeworks
- Participate in practice sessions 2h / wk
- Read and study independently
- Take course exam 8h ?

TiKRa Fall 1999 exam vs. homework points (hwp)

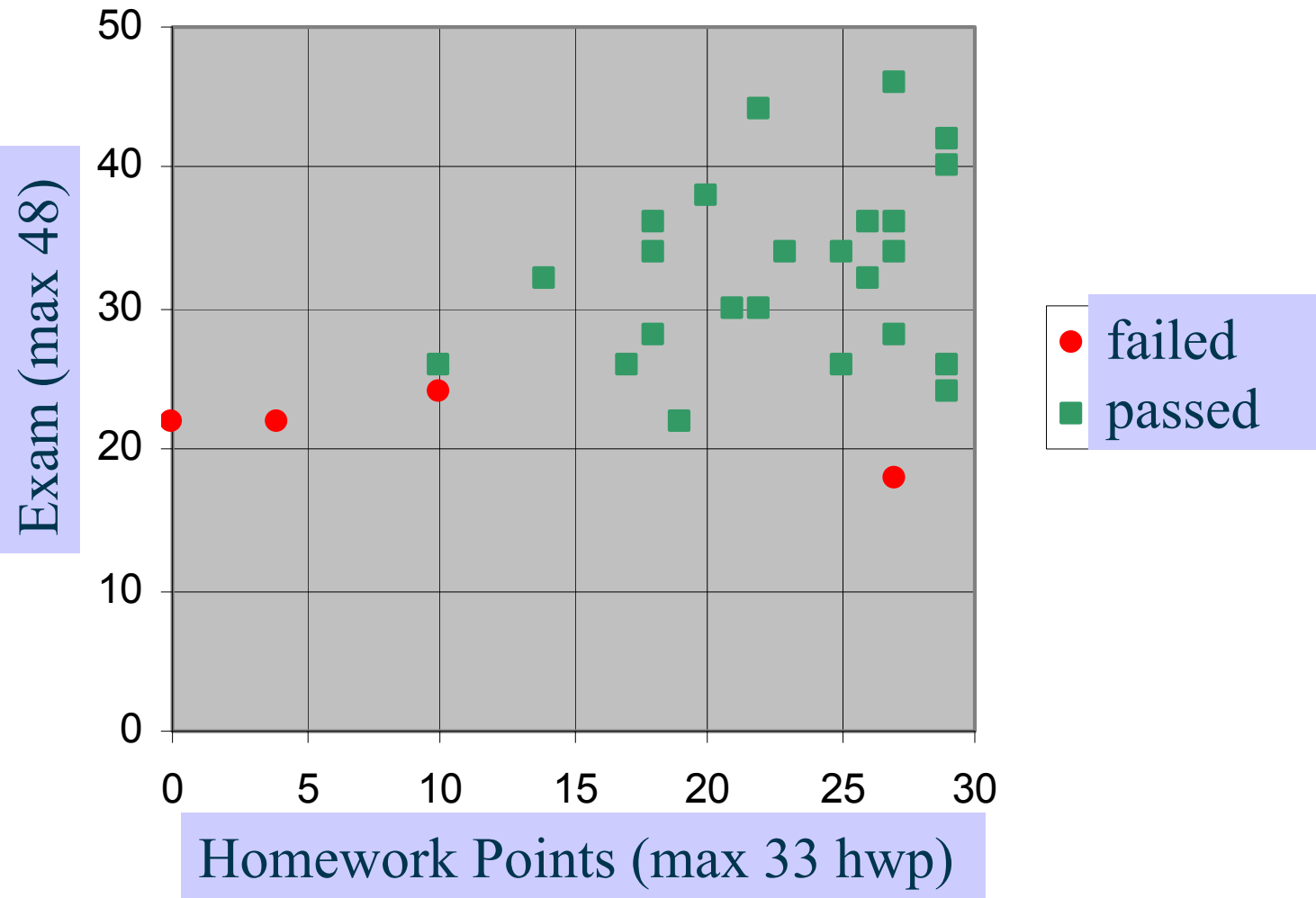

TiKRa Fall 2000 exam vs. homework points (hwp)

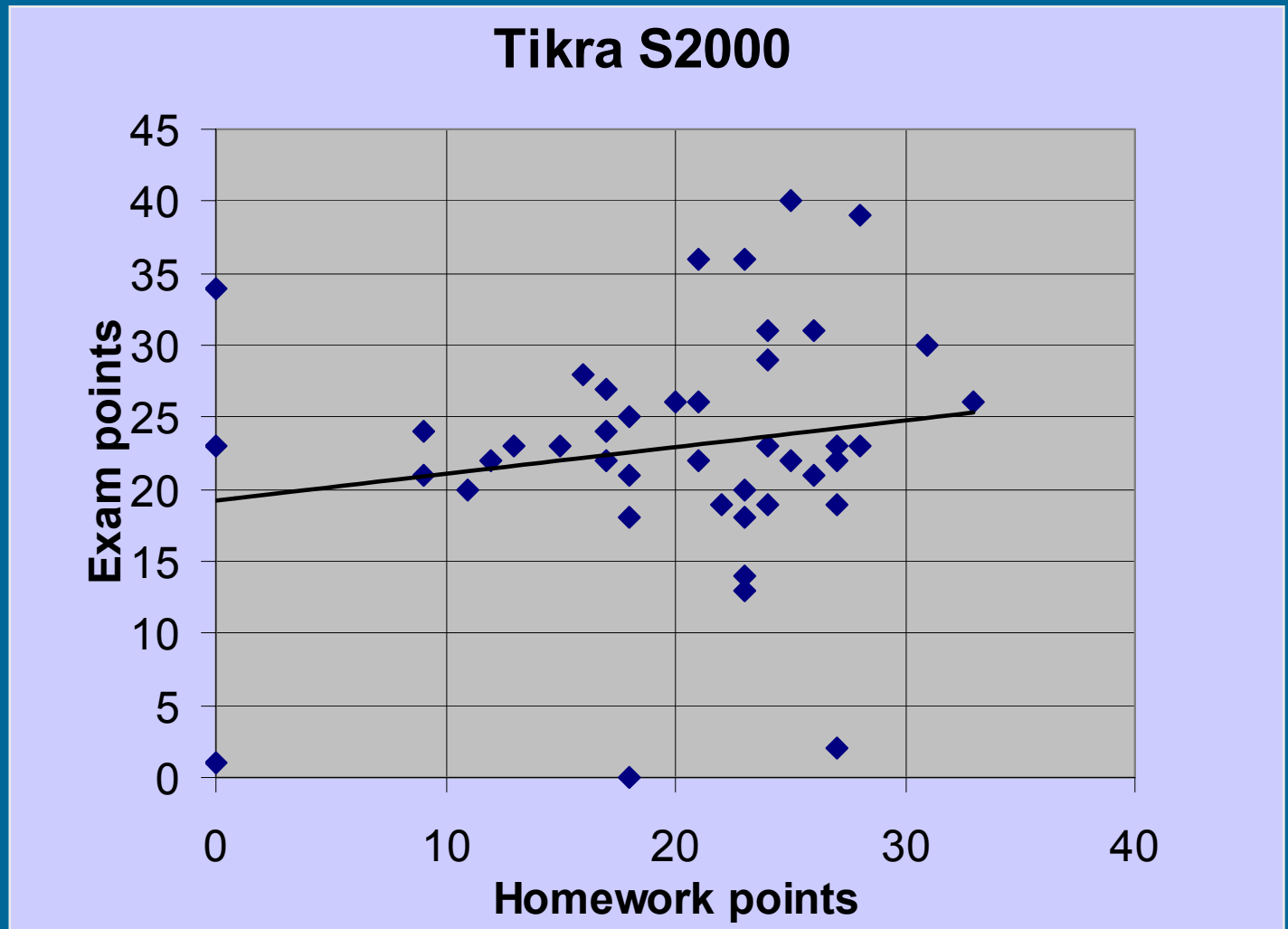

WWW Information

- Course home page
<http://www.cs.helsinki.fi/Teemu.Kerola/tikra/>
- This semester schedule
<.../tikra/S2003/aikataulu.html>
- Lectures
<.../luennot/>
- Homeworks
<.../laskuharj/>
- Old exams
<.../tikra/kokeet/>
- Newsgroup
<hy.opiskelu.tktl.tikra>

A := B + C;

High level language



```
MOV AX, B  
ADD AX, C  
MOV A, AX
```

Assembler

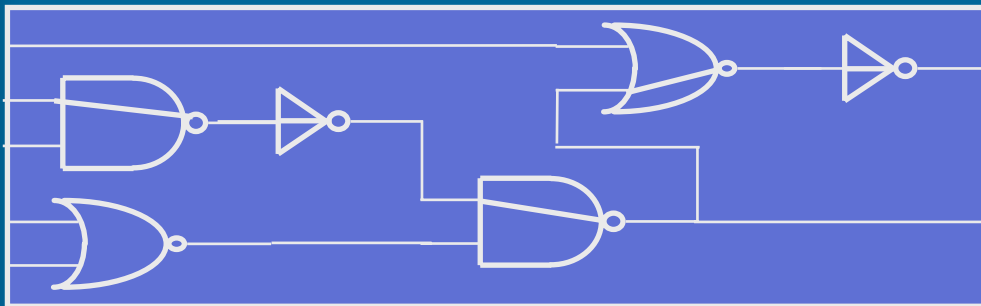

Logic circuits

Comp. Org. I
(TiTo,
Tietokoneen
toiminta)

Comp. Org. II
(TiKRä,
Tietokoneen
rakenne)

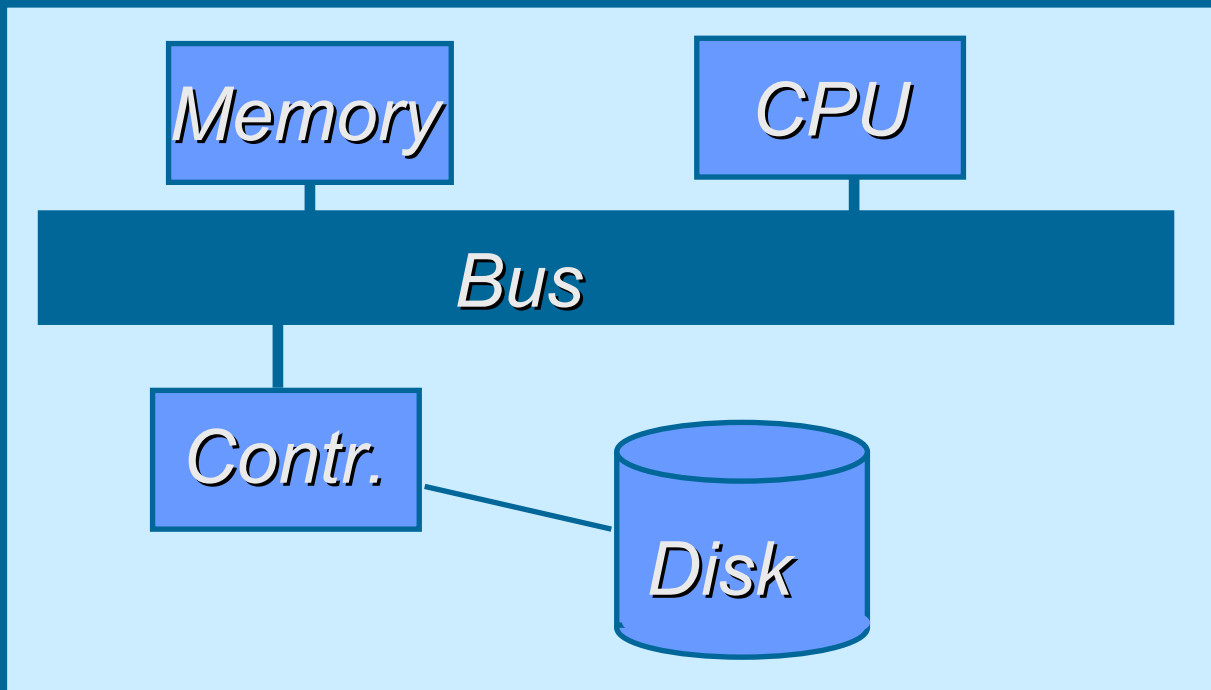

TiTo: What happens is system

TiKRa: How are CPU & memory implemented?

The Lowest Presentation Level for Comp Org I (TiTo)

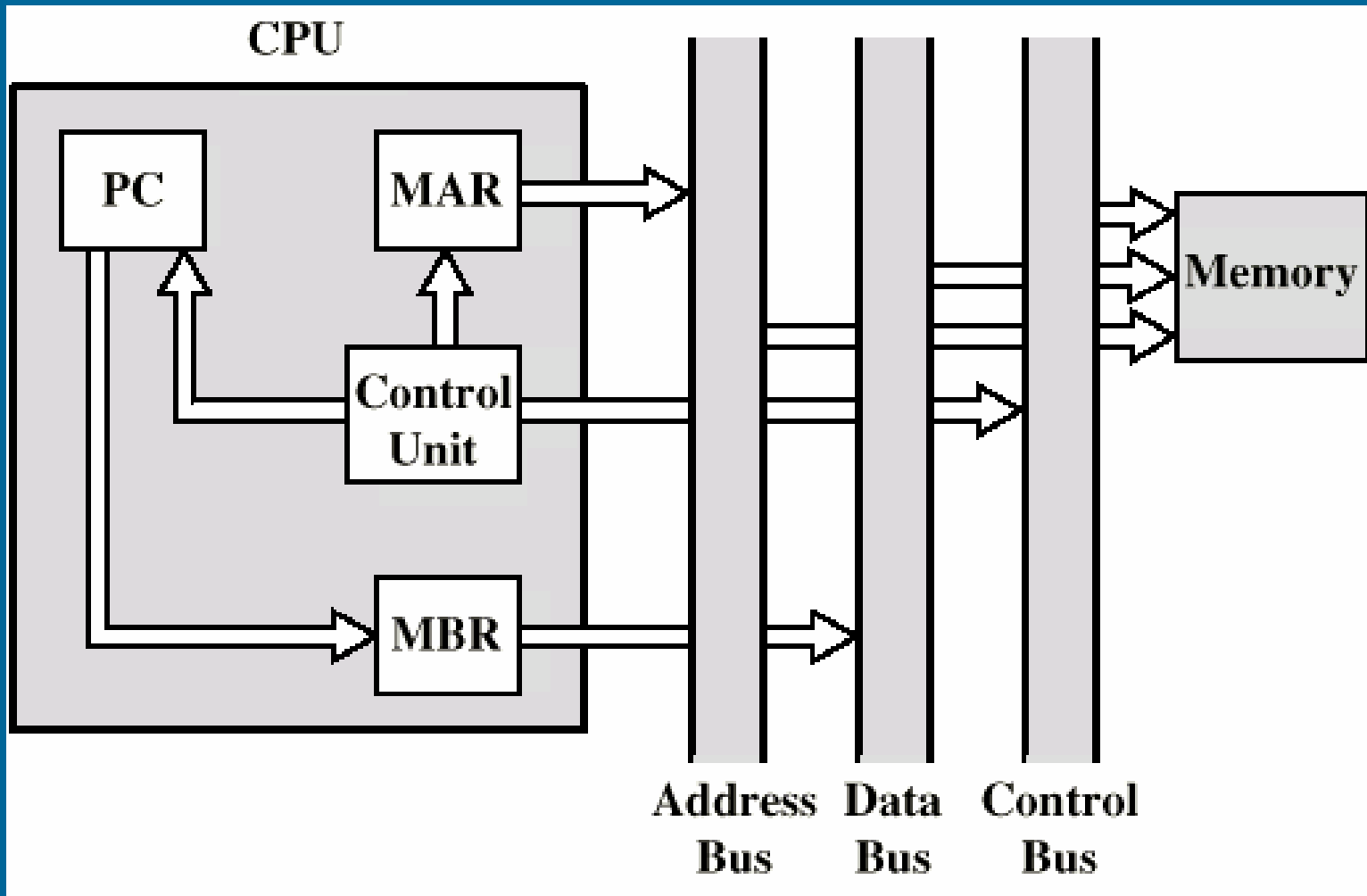

The Lowest Presentation Level for Comp Org II (TiKRa)

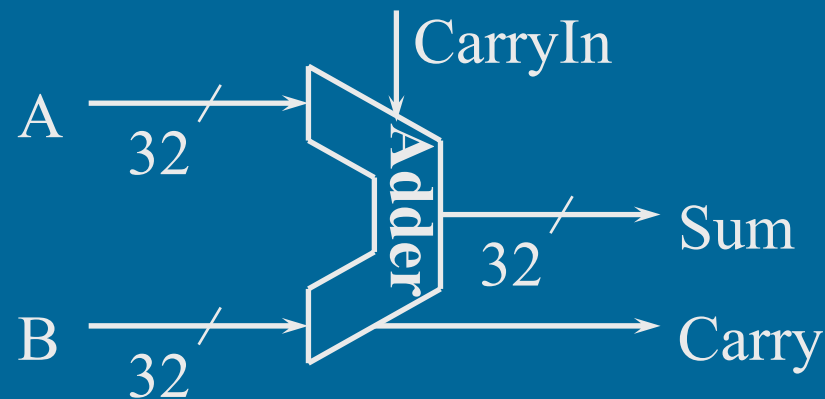
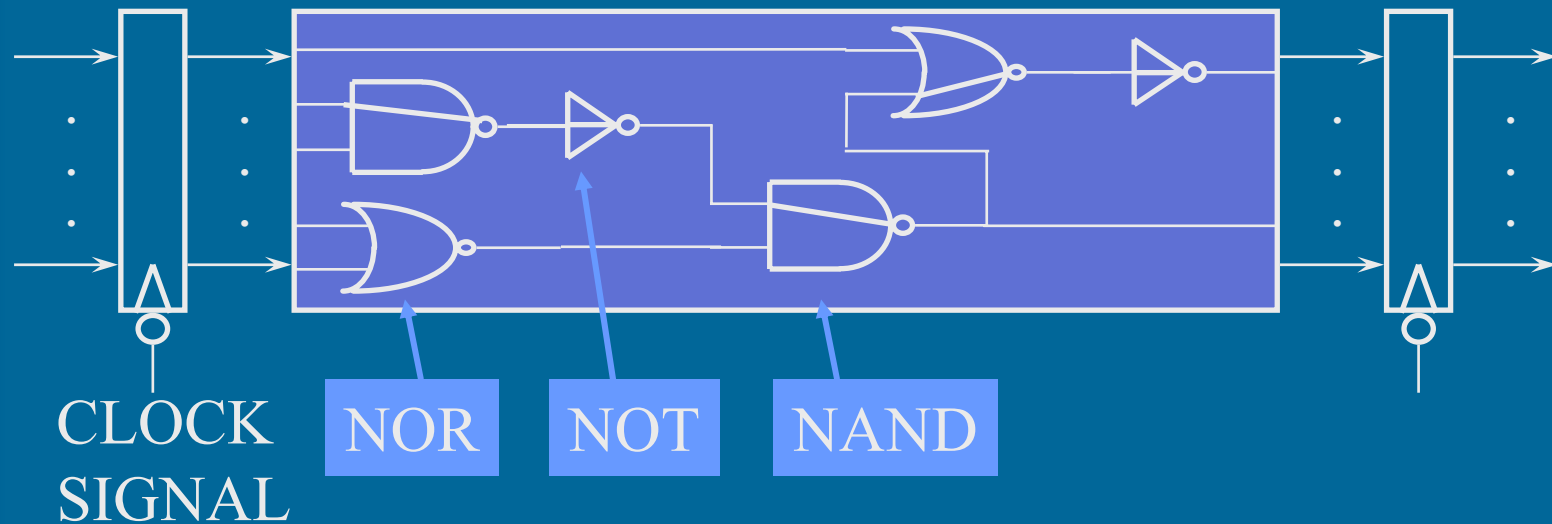

Contents

Text book: Stallings, Computer Organization & Architecture, 6th Ed., 2003

Old text book: 5th Ed, 1999

- Computer system - overall structure (Ch 1-8) (Ch 1-7)
- System buses (Ch 3) (Ch 3) 5th Ed, [Stal99]
- Digital logic (App A) (App A)
- Memory hierarchy (Ch 4.3, 8.3) (Ch 4.3, 7.3)
- Computer arithmetic (Ch 9) (Ch 8)
- Instruction sets (Ch 10-11) (Ch 9-10)
- CPU structure and function (Ch 12) (Ch 10)
- Reduced Instruction Set Computers (Ch 13) (Ch 12)
- Instr. level parall. and superscalar proc. (Ch 14) (Ch 13)
- IA-64 (Ch 15) & Crusoe
- Control unit (Ch 16-17), Summary (Ch 14-15)