

# Memory Hierarchy and Cache

## Ch 4-5

### Memory Hierarchy

Main Memory  
Cache  
Implementation

24.9.2003

Copyright Teemu Kerola 2003

1

## Teemu's Cheesecake

Fig. 4.1

Register, on-chip cache, memory, disk, and tape speeds relative to times locating cheese for the cheese cake you are baking...

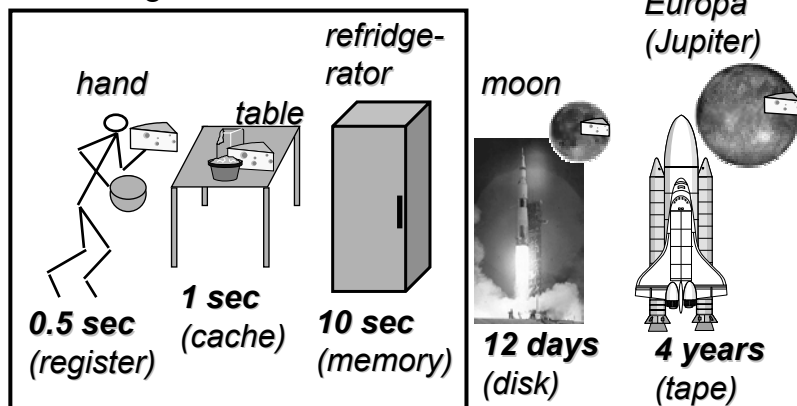

24.9.2003

Copyright Teemu Kerola 2003

2

## Goal <sup>(4)</sup>

- I want my memory lightning fast
- I want my memory to be gigantic in size
- Register access viewpoint:
  - data access as fast as HW register
  - data size as large as memory
- Memory access viewpoint
  - data access as fast as memory
  - data size as large as disk

cache

HW solution

virtual  
memory

HW help for  
SW solution

## Memory Hierarchy <sup>(5)</sup>

Fig. 4.1

- Most often needed data is kept close
- Access to small data sets can be made fast
  - simpler circuits
- Faster is more expensive
- Large can be bigger and cheaper (per byte)

### Memory Hierarchy

up: smaller, faster, more expensive,  
more frequent access

down: bigger, slower, less expensive,  
less frequent access

## Principle of locality (8)

(paikallisuus)

- In any given time period, memory references occur only to a small subset of the whole address space
- The reason why memory hierarchies work

Prob ( small data set ) = 99%  
Prob ( the rest ) = 1%

Cost ( small data set ) = 2  $\mu$ s  
Cost ( the rest ) = 20  $\mu$ s

$$\text{Aver cost } 99\% * 2 \mu\text{s} + 1\% * 20 \mu\text{s} = 2.2 \mu\text{s}$$

Fig. 4.2

- Average cost is close to the cost of small data set
- How to determine data for that small set?
- How to keep track of it?

24.9.2003

Copyright Teemu Kerola 2003

5

## Principle of locality (5)

- In any given time period, memory references occur only to a small subset of the whole address space

(paikallisuus)

- Temporal locality: it is likely that a data item referenced a short time ago will be referenced again soon

(ajallinen paikallisuus)

- Spatial locality: it is likely that a data items close to the one referenced a short time ago will be referenced soon

(alueellinen paikallisuus)

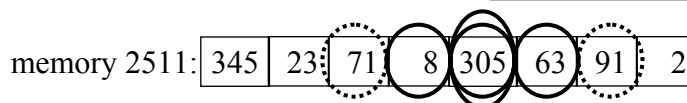

24.9.2003

Copyright Teemu Kerola 2003

6

# Memory

- Random access semiconductor memory
  - give address & control, read/write data
- ROM, PROMS, FLASH
  - system startup memory, BIOS (Basic Input/Output System)
    - load and execute OS at boot
  - also random access
- RAM
  - “normal” memory accessible by CPU

Table 5.1

(Table 4.2 [Stall99])

## RAM

E.g., \$0.12 / MB  
(year 2001)

- Dynamic RAM, DRAM
  - simpler, slower, denser, bigger (bytes per chip)
  - main memory?
    - E.g., 60 ns access
  - periodic refreshing required
  - refresh required after read
- Static RAM, SRAM
  - E.g., \$0.70 / MB (year 2001)
  - more complex (more chip area/byte), faster, smaller (bytes per chip)
    - E.g., 5 ns access?
  - cache?
  - no periodic refreshing needed
  - data remains until power is lost

# DRAM Access

- 16 Mb DRAM
  - 4 bit data items Fig. 5.3 (Fig. 4.4 [Stal99])
  - 4M data elements, 2K \* 2K square
  - Address 22 bits Fig. 5.4 (b) (Fig. 4.5 (b) [Stal99])
    - row access select (RAS)
    - column access select (CAS)
    - interleaved on 11 address pins
- Simultaneous access to many 16Mb memory chips to access larger data items
  - Access 8 bit words in parallel? Need 8 chips.

Fig. 5.5 (Fig. 4.6 [Stal99])

# SDRAM (Synchronous DRAM)

- 16 bits in parallel
  - access 4 DRAMs (4 bits each) in parallel
- CPU clock synchronizes also the bus
  - not by separate clock for the bus
  - CPU knows how long it takes make a reference – it can do other work while waiting
- Faster than plain DRAM
- Current main memory technology (year 2001)

E.g., \$0.11 / MB (year 2001)

# RDRAM (RambusDRAM)

- New technology, works with fast memory bus
  - expensive E.g., \$0.40 / MB (year 2001)?
- Faster transfer rate than with SDRAM
  - E.g., 1.6 GB/sec vs. 200 MB/sec (?)
- Faster access than SDRAM
  - E.g., 38 ns vs. 44 ns
- Fast internal Rambus channel (800 MHz)
- Rambus memory controller connects to bus
- Speed slows down with many memory modules
  - serially connected on Rambus channel
  - not good for servers with 1 GB memory (for now!)
- 5% of memory chips (year 2000), 12% (2005)?

24.9.2003

Copyright Teemu Kerola 2003

11

# Flash memory

- Original invention
  - Fujio Masuoka, Toshiba Corp., 1984
  - non-volatile, data remains with power off
  - slow to write (“program”)
- Nand-Flash, 1987
  - Fujio Masuoka
  - lowers the wiring per bit to one-eighth that of the Flash Memory's



24.9.2003

Copyright Teemu Kerola 2003

12

# Intel ETOX Flash

- Intel, 1997
- A single transistor with the addition of an electrically isolated polysilicon floating gate capable of storing charge (electrons)
- Negatively charged electrons act as a barrier between the control gate and the floating gate.
- Depending on the flow through the floating gate (more or less than 50%) it has value 1 or 0.
- Read/Write data in small blocks

use high voltage to write, and "Fowler-Nordheim Tunneling" to clear

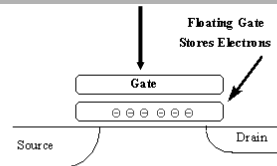

[http://developer.intel.com/technology/itj/q41997/articles/art\\_1.htm](http://developer.intel.com/technology/itj/q41997/articles/art_1.htm)

24.9.2003

Copyright Teemu Kerola 2003

13

# Intel StrataFlash

- Flash cell is analog, not digital storage
- Use different charge levels to store 2 bits (or more!) of data in each flash cell

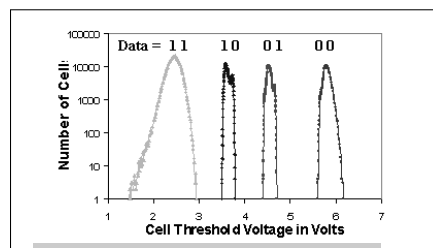

[http://developer.intel.com/technology/itj/q41997/articles/art\\_1.htm](http://developer.intel.com/technology/itj/q41997/articles/art_1.htm)

24.9.2003

Copyright Teemu Kerola 2003

14

# Flash Implementations

- BIOS (PC's, phones, other hand-held devices....)
- Toshiba SmartMedia, 2-256 MB ....
- Sony Memory Stick, 2-1024 MB
- CompactFlash, 8-512 MB .....
- PlayStation II Memory Card, 8 MB
- MMC - MultiMedia Card, 32-128 MB
- Fuji XD Picture Card 32-256 MB
- Hand-held phone memories





# Cache Memory

(välimuisti)

- Problem: how can I make my (main) memory as fast as my registers?
- Answer: (processor) cache
  - keep most probably referenced data in fast cache close to processor, and rest of it in memory
    - much smaller than main memory
    - (much) more expensive (per byte) than memory
    - most of data accesses only to cache

90% 99%?

Fig. 4.3 & 4.6 (Fig. 4.13 & 4.16 [Stal99])

## Memory references with cache (5)

- Data is in cache?

Hit

Data is only in memory?

Miss

Read it to cache

Fig. 4.5

CPU waits until data available

(Fig. 4.15 [Stall99])

Many blocks (cache lines) help for temporal locality  
many different data items in cache

Fig. 4.4

Large blocks help for spatial locality  
lots of “nearby” data available

(Fig. 4.14 [Stall99])

Fixed cache size?

Select “many” or “large”? (can not have both!)

# Cache Features <sup>(6)</sup>

- Size
- Mapping function (kuvausfunktio)
  - how to find data in cache?
- Replacement algorithm (poistoalgoritmi)
  - which block to remove to make room for a new block?
- Write policy (kirjoituspolitiikka)
  - how to handle writes?
- Line size (block size)? (rivin tai lohkon koko)
- Number of caches? Types of caches?

24.9.2003

Copyright Teemu Kerola 2003

19

# Cache Size

- Bigger is better in general
- Bigger may be slower
  - lots of gates, cumulative gate delay?
- Too big might be too slow!
  - Help: 2- or 3-level caches

1KW (4 KB),  
128MW (512 MB)?

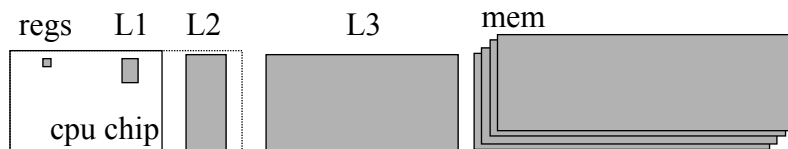

24.9.2003

Copyright Teemu Kerola 2003

20

## Mapping: Memory Address (3)

- Alpha AXP issues 34 bit memory addresses
  - Use block address to locate block in cache
  - With cache hit, block offset is controlling a multiplexer to select right word

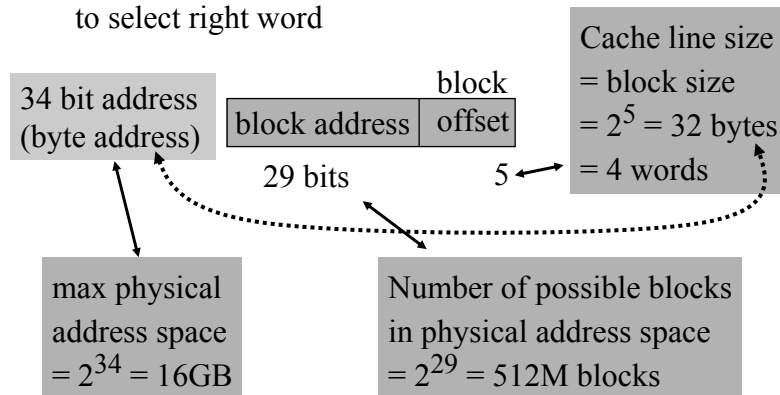

24.9.2003

Copyright Teemu Kerola 2003

21

## Mapping (2)

- Given a memory block address,
  - is that block in cache?
  - where is it there?
- Three solution methods
  - direct mappings
  - fully associative mapping
  - set associative mapping

24.9.2003

Copyright Teemu Kerola 2003

22

# Direct Mapping (6)

(suora kuvaus)

- Every block has only one possible location (cache line number) in cache
  - determined by index field bits

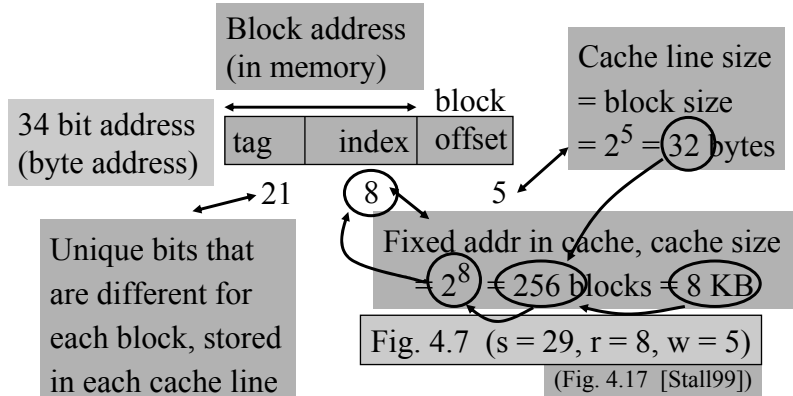
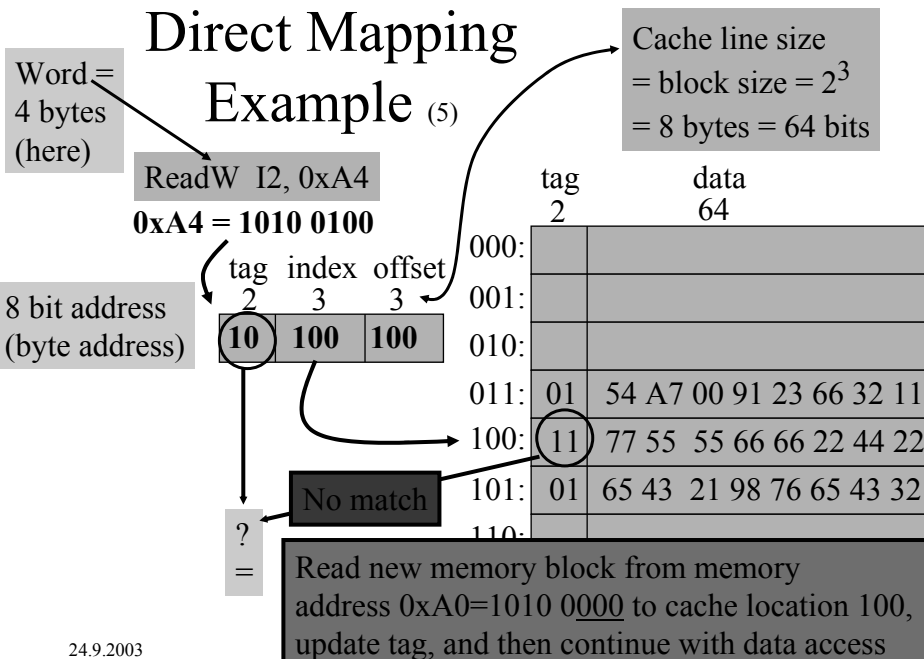
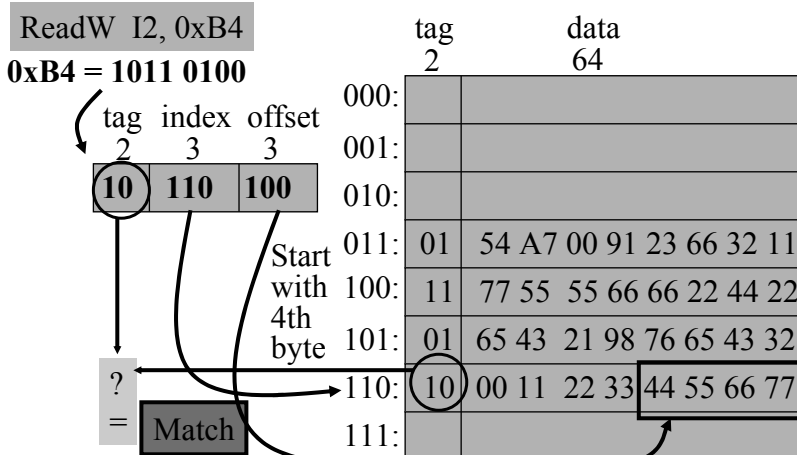

Fig. 7.10 [PaHe98]

# Direct Mapping Example (5)



# Direct Mapping Example 2 <sup>(5)</sup>



# Fully Associative Mapping <sup>(5)</sup>

(täysin assosiaatiivinen kuvaus)

- Every block can be in any cache line
  - tag must be complete block address

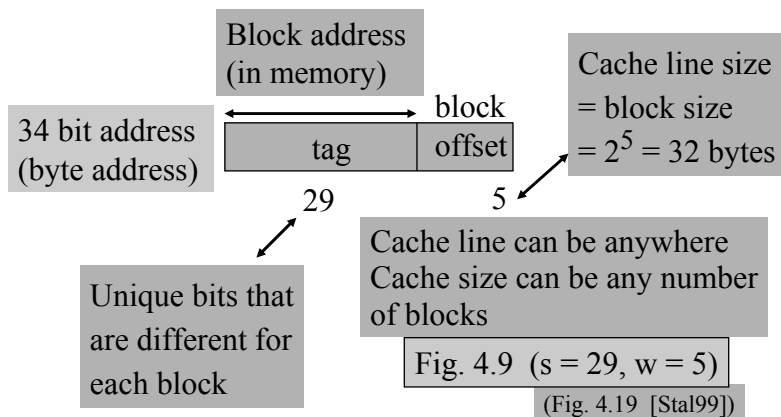

# Fully Associative Example (5)

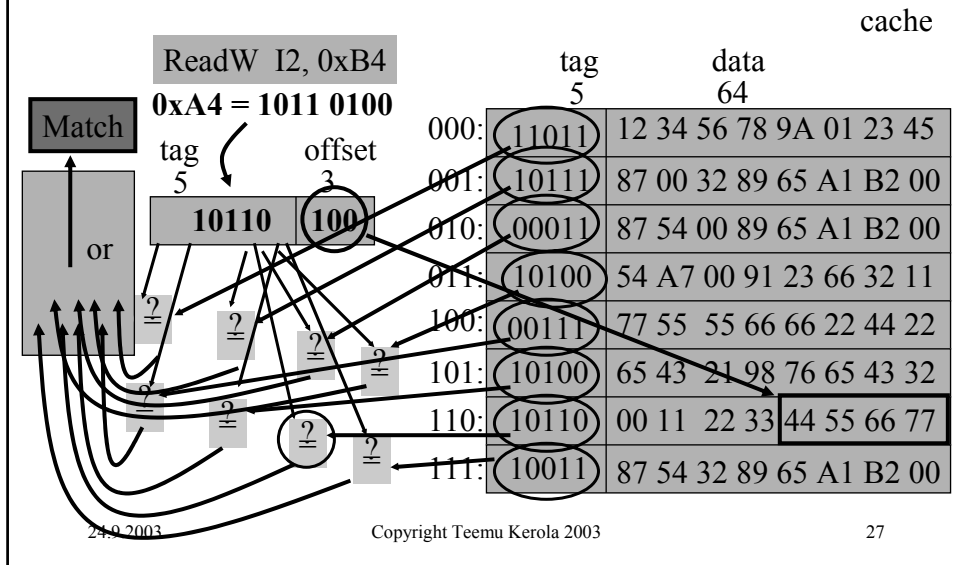

## Fully Associative Mapping

- Lots of circuits
  - tag fields are long - wasted space!
  - each cache line tag must be compared simultaneously with the memory address tag
    - lots of wires
    - lots of comparison circuits
- Final comparison “or” has large gate delay
  - did any of these 64 comparisons match?
    - $2^{\log(64)} = 8$  levels of binary or-gates
  - how about 262144 comparisons? 18 levels?
- $\Rightarrow$  Can use it only for small caches

# Set Associative Mapping (6)

(joukkoassosiatiivinen kuvaus)

- With set size  $k=2$ , every block has 2 possible locations in cache

– Possible location of block is determined by *set (index)* field bits

34 bit address  
(byte address)

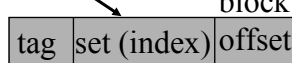

Cache line size  
= block size  
=  $2^5 = 32$  bytes

Unique bits that are different for each block, stored in each cache line

Nr of sets  $v=2^7=128$  blocks = 4 KB

Total cache size  $vk=2*4$  KB= 8 KB

Fig. 5.8 [HePa96]

Fig. 7.19 [PaHe98]

Fig. 4.11 (confusing, complex?)  
(E.g.,  $k=2$ ,  $s = 29$ ,  $d = 7$ ,  $w = 5$ )

(Fig. 4.21 [Stal99])

24.9.2003

Copyright Teemu Kerola 2003

29

## Two definitions for "Set" in "Set Associative Mapping"

- Term "set" is the set of all possible locations where referenced memory block can be
  - Field "set" of memory address determines this set
  - [Stal03], [Stal99]
- Cache memory is split into multiple "sets", and the referenced memory block can be in only one location in each "set"
  - Field "index" of memory address determines possible location of referenced block in each "set"
  - [HePa96], [PaHe98]

24.9.2003

Copyright Teemu Kerola 2003

30

# Two definitions for "Set" in "Set Associative Mapping"

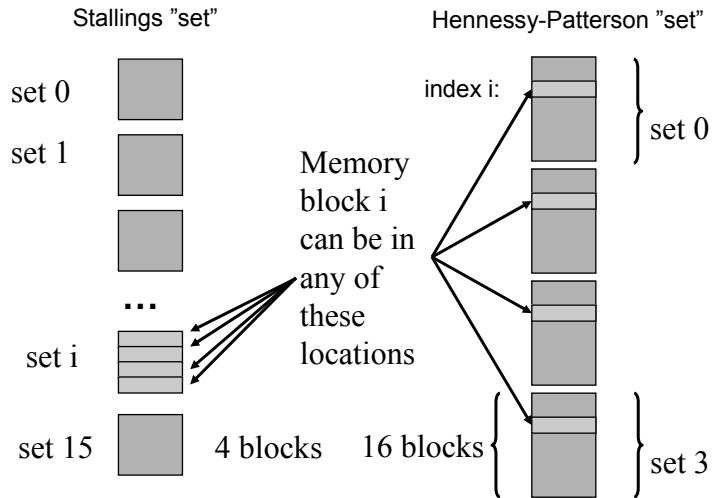

24.9.2003

Copyright Teemu Kerola 2003

31

# 2-way Set Associative Cache

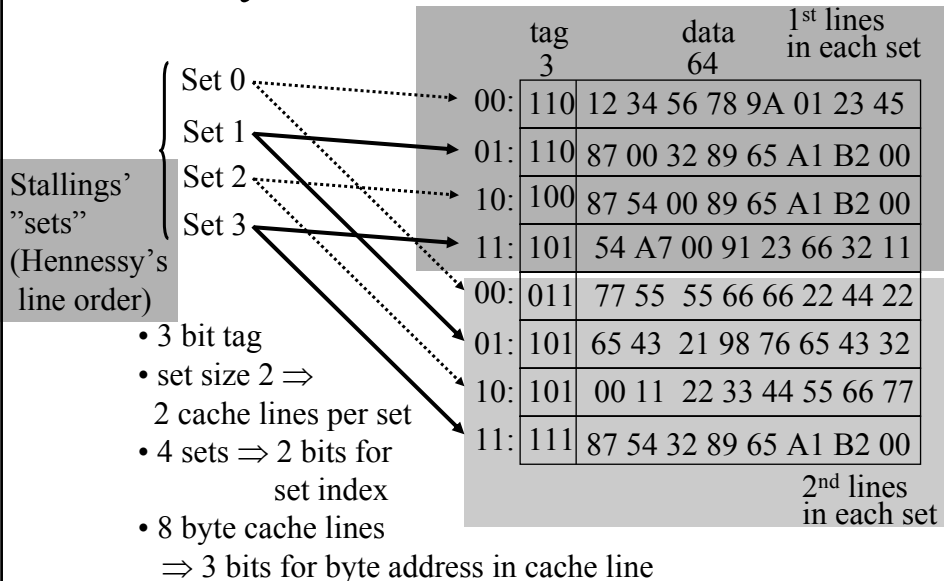

24.9.2003

Copyright Teemu Kerola 2003

32



# Set Associative Example (6)

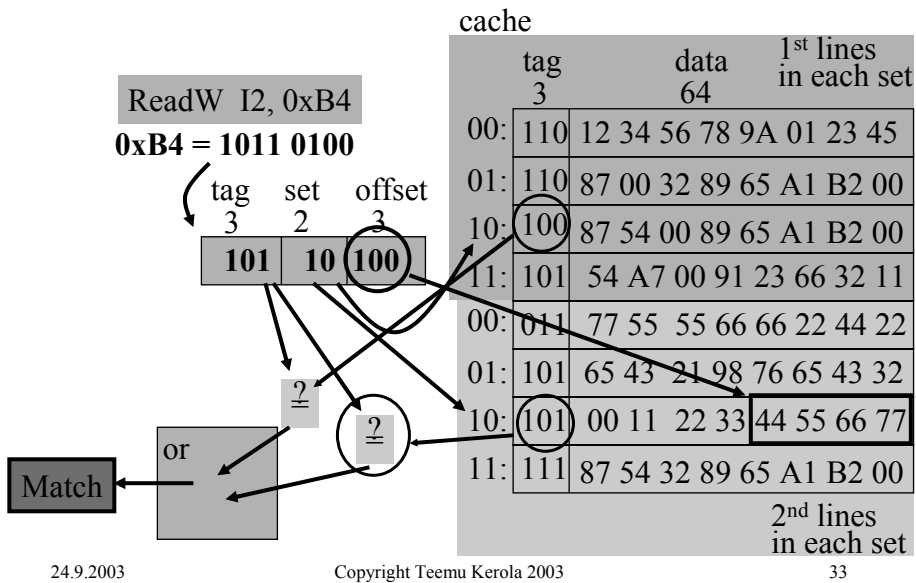

## Set Associative Mapping

- Set associative cache with set size 2  
= 2-way cache
- Degree of associativity  $v$ ? Usually 2
  - $v$  large? Fig. 7.16 [PaHe98]
    - More data items ( $v$ ) in one set
    - less “collisions” within set
    - final comparison (matching tags?) gate delay?
  - $v$  maximum (nr of cache lines)  
⇒ fully associative mapping
  - $v$  minimum (1) ⇒ direct mapping

# Replacement Algorithm

- Which cache block (line) to remove to make room for new block from memory?
- Direct mapping case trivial
- First-In-First-Out (FIFO)
- Least-Frequently-Used (LFU)
- Random
- Which one is best?
  - Chip area?
  - Fast? Easy to implement?

# Write Policy

- How to handle writes to memory?
- Write through (läpikirjoittava)
  - each write goes always to memory
  - each write is a cache miss!
- Write back (lopuksi kirjoittava takaisin kirjoittava?)
  - write cache block to memory only when it is replaced in cache
  - memory may have stale (old) data
  - cache coherence problem (välimuistin yhteneväisyysongelma)

# Line size

- How big cache line?
- Optimise for temporal or spatial locality?
  - bigger cache line is better for spatial locality
  - More cache lines is better for temporal locality
- Data references and code references behave in a different way
- Best size varies with program or program phase
- 2-8 words?
  - word = 1 float??

# Number/types of Caches <sup>(3)</sup>

- One cache too large for best results
- Unified vs. split cache (yhdistetty, erilliset)
  - same cache for data and code, or not?
  - split cache: can optimise structure separately for data and code
- Multiple levels of caches
  - L1 - same chip as CPU
  - L2 - same package or chip as CPU
    - older systems: same board
  - L3 - same board as CPU

Fig. 4.13

(Fig. 4.23 [Stal99])

-- End of Ch. 4-5: Cache Memory --

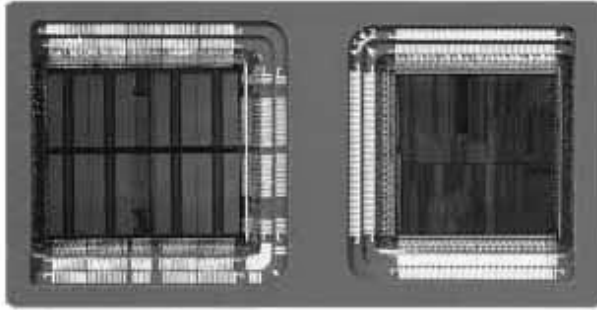

<http://www.intel.com/procs/servers/feature/cache/unique.htm>

“The Pentium® Pro processor's unique multi-cavity chip package brings L2 cache memory closer to the CPU, delivering higher performance for business-critical computing needs.”