

CPU Structure and Function

Ch 12

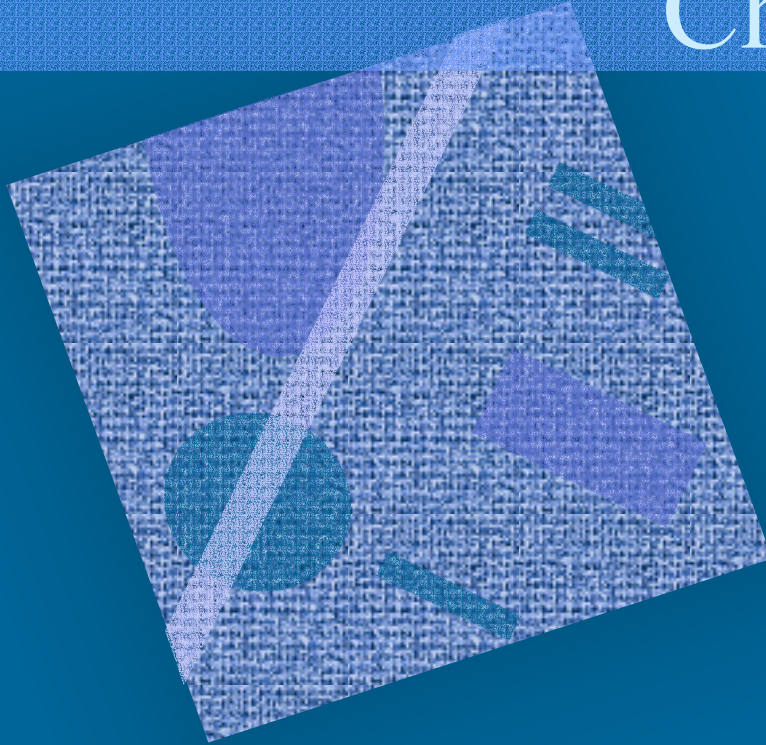

General Organisation
Registers
Instruction Cycle
Pipelining
Branch Prediction
Interrupts

General CPU Organization (4)

- ALU
 - does all real work
- Registers
 - data stored here
- Internal CPU Bus
- Control
 - determines who does what when
 - driven by clock
 - uses control signals (wires) to control what every circuit is doing at any given clock cycle

Fig. 12.1 (Fig. 11.1 [Stal99])

Fig. 12.2 (Fig. 11.2 [Stal99])

More in Chapters 16-17 (Ch 14-15 [Stal99])

Register Organisation (4)

- Registers make up CPU work space
- User visible registers `ADD R1,R2,R3`
 - accessible directly via instructions
- Control and status registers `BNeq Loop`
 - may be accessible indirectly via instructions
 - may be accessible only internally `HW exception`
- Internal latches for temporary storage during instruction execution
 - E.g., ALU operand either from constant in instruction or from machine register

User Visible Registers (6)

- Varies from one architecture to another
- General purpose registers (GPR)
 - Data, address, index, PC, condition,
- Data registers
 - Int, FP, Double, Index
- Address registers
- Segment and stack pointers
 - only privileged instruction can write?
- Condition codes
 - result of some previous ALU operation

Control and Status Registers (5)

- PC
 - next instruction (not current!)
 - part of process state
- IR, Instruction (Decoding) Register
 - current instruction
- MAR, Memory Address Register
 - current memory address
- MBR, Memory Buffer Register
 - current data to/from memory
- PSW, Program Status Word
 - what is allowed? What is going on?
 - part of process state

Fig. 12.7

(Fig. 11.7 [Stal99])

PSW - Program Status Word (6)

- State info from latest ALU-op
 - Sign, zero?
 - Carry (for multiword ALU ops)?
 - Overflow?
- Interrupts that are enabled/disabled?
- Pending interrupts?
- CPU execution mode (supervisor, user)?
- Stack pointer, page table pointer?
- I/O registers?

Instruction Cycle (4)

Fig. 11.4 [Stal99]

- Basic cycle with interrupt handling
- Indirect cycle Figs 12.4-5 (Fig. 11.5-6 [Stal99])
- Data Flow Figs 12.6-8 (Fig. 11.7-9 [Stal99])
 - CPU, Bus, Memory
- Data Path Fig 16.5 (Fig. 14.5 [Stal99])
 - CPU's “internal data bus” or “data mesh” Fig 3.1 [HePa96]
 - All computation is data transformations occurring on the data path
 - Control signals determine data flow & action for each clock cycle

Pipeline Example

(liukuhinna)

- Laundry Example (David A. Patterson)
- Ann, Brian, Cathy, Dave each have one load of clothes to wash, dry, and fold

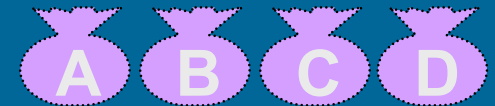

- Washer takes 30 minutes



- Dryer takes 40 minutes



- “Folder” takes 20 minutes



Sequential Laundry (7)

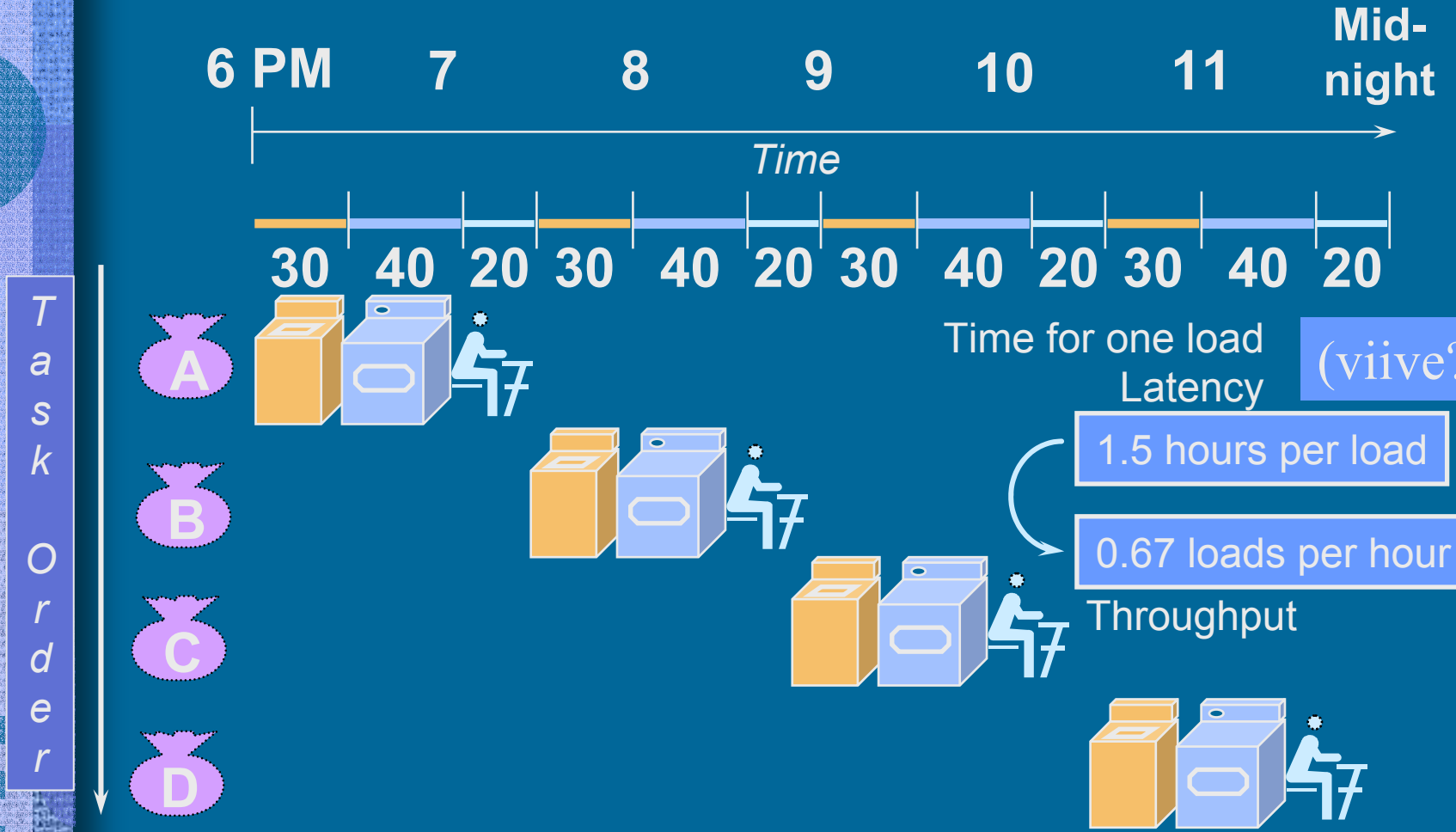

- Sequential laundry takes 6 hours for 4 loads
- If they learned pipelining, how long would laundry take?

Pipelined Laundry (11)

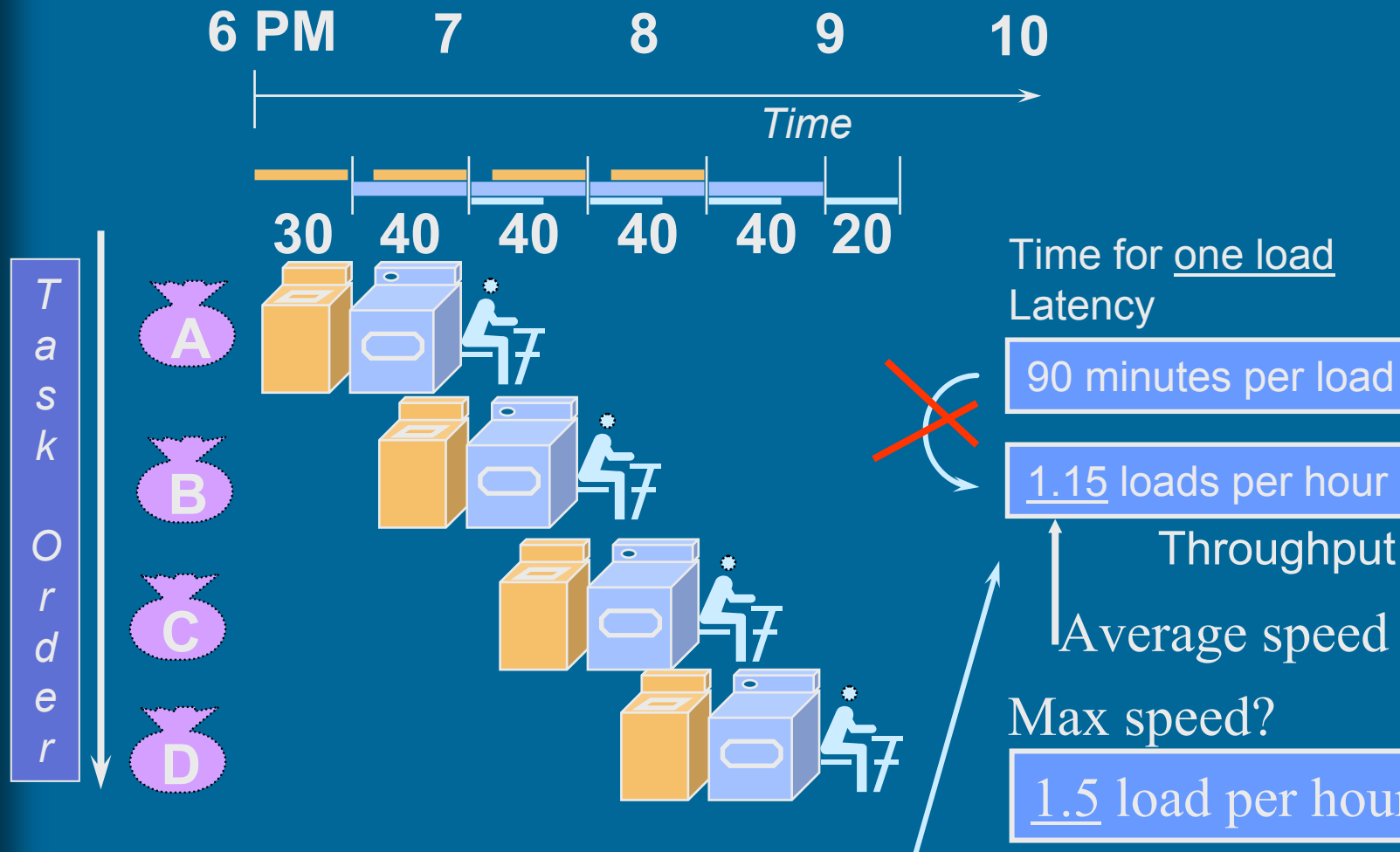

- Pipelined laundry takes 3.5 hours for 4 loads
- At best case, laundry is completed every 40 minutes

Pipelining Lessons (4)

- Pipelining doesn't help latency of single task, but it helps throughput of the entire workload
- Pipeline rate limited by slowest pipeline stage
- Multiple tasks operating simultaneously
- Potential speedup
= maximum possible speedup
= Number pipe stages

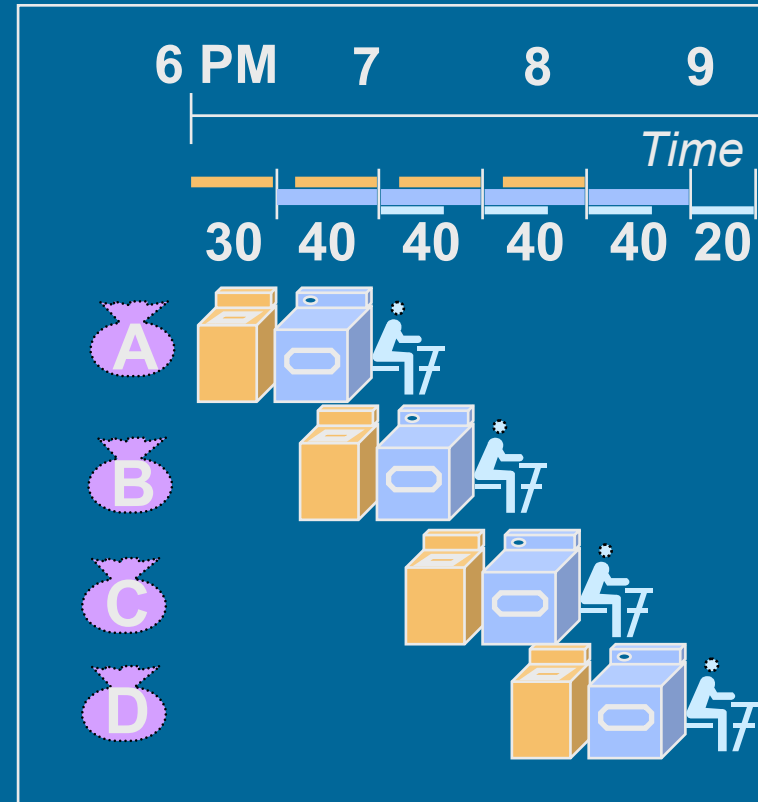

(nopeutus)

Pipelining Lessons (3)

- Unbalanced lengths of pipe stages reduces speedup
- May need more resources
 - Enough electrical current to run both washer and dryer simultaneously?
 - Need to have at least 2 people present all the time?
- Time to “fill” pipeline and time to “drain” it reduces speedup

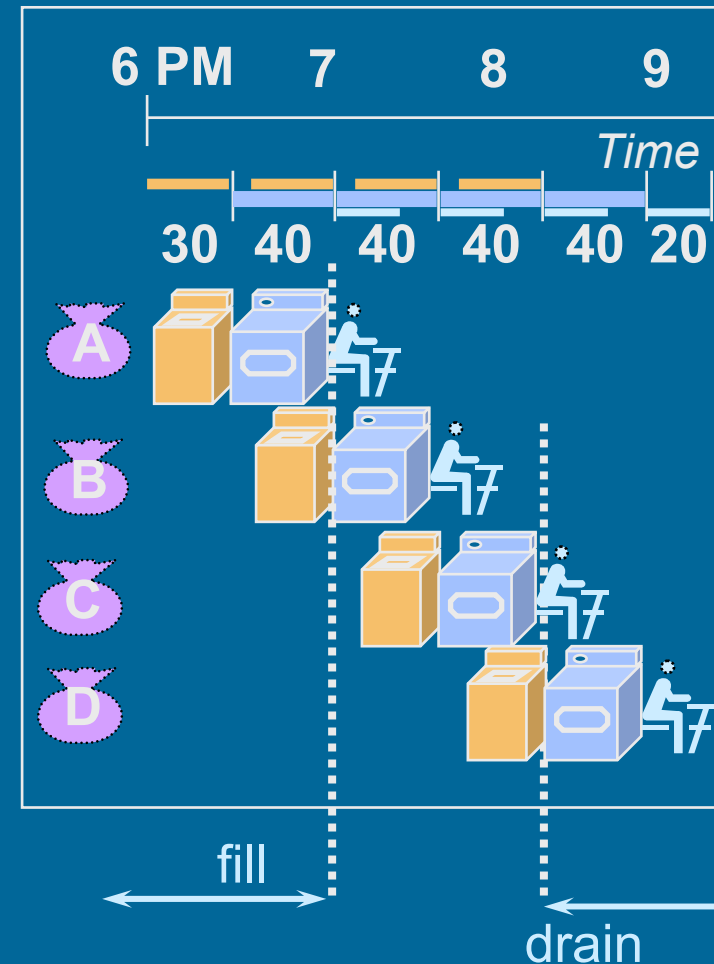

2-stage Instruction Execution Pipeline (4)

Fig. 12.9

(Fig. 11.10 [Stal99])

- Good: instruction pre-fetch at the same time as execution of previous instruction
- Bad: execution phase is longer, I.e., fetch stage is sometimes idle
- Bad: Sometimes (jump, branch) wrong instruction is fetched
 - every 6th instruction?
- Not enough parallelism \Rightarrow more stages?

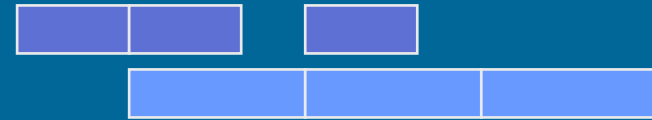

Another Possible Instruction Execution Pipeline

- FE - Fetch instruction
- DI - Decode instruction
- CO - Calculate operand effective addresses
- FO - Fetch operands from memory
- EI - Execute Instruction
- WO - Write operand (result) to memory

Fig. 12.10 (Fig. 11.11 [Stal99])

Pipeline Speedup (6)

No pipeline, 9 instructions

$9 * 6$

54 time units

6 stage pipeline, 9 instructions

Fig. 12.10

(Fig. 11.11 [Stal99])

14 time units

$$\text{Speedup} = \frac{\text{Time}_{\text{old}}}{\text{Time}_{\text{new}}} = 54/14 = 3.86 < 6 !$$

(nopeutus)

- Not every instruction uses every stage
 - serial execution actually even faster
 - speedup even smaller
 - will not affect pipeline speed
 - unused stage \Rightarrow CPU idle (execution “bubble”)

Pipeline Execution Time (3)

- Time to execute one instruction , I.e., latency may be longer than for non-pipelined machine
 - extra latches to store intermediate results
- Time to execute 1000 instructions (seconds) is shorter (better) than that for non-pipelined machine, I.e., throughput (instructions per second) for pipelined machine is better (bigger) than that for non-pipelined machine
 - parallel actions speed-up overall work load
- Is this good or bad? Why?

Pipeline Speedup Problems

- Some stages are shorter than the others
- Dependencies between instructions
 - control dependency
 - E.g., conditional branch decision know only after EI stage

Fig. 12.11 (Fig. 11.12 [Stal99])

Fig. 12.12-13 (Fig. 11.13 [Stal99])

Pipeline Speedup Problems (3)

Fig. 12.11 (Fig. 11.12 [Stal99])

- Dependencies between instructions

- data dependency

- One instruction depends on data produced by some earlier instruction

- structural dependency

- Many instructions need the same resource at the same time
- memory bus, ALU, ...

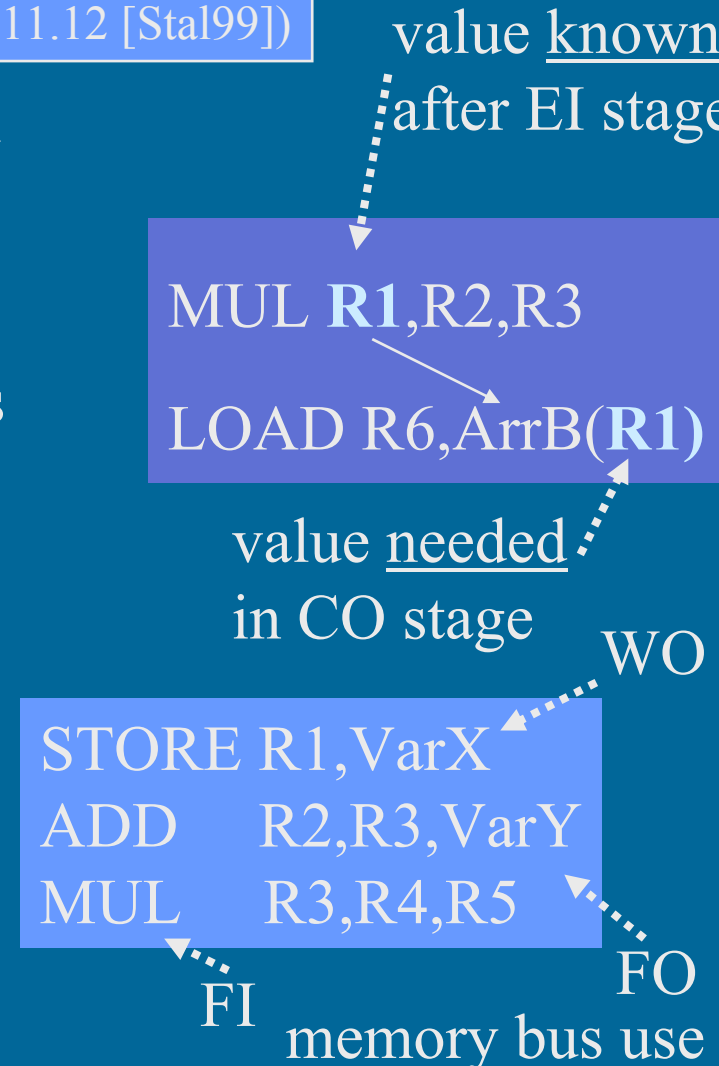

Cycle Time ⁽³⁾

$$\tau = \max[\tau_i] + d = \tau_m + d \gg d$$

(min) cycle time

gate delay in stage i

max gate delay in stage
delay in latches between stages
(= clock pulse, or clock cycle time)

overhead?

- Cycle time is the same for all stages
 - time (in clock pulses) to execute the stage
- Each stage takes one cycle time to execute
- Longest stage determines min cycle time
 - max MHz rate for system clock

Pipeline Speedup (1)

n instructions, k stages

n instructions, k stages
 τ = stage delay = cycle time

Time
not pipelined:

$$T_1 = nk\tau$$

(pessimistic because of
assuming that each stage
would still have τ cycle time)

Time
pipelined:

$$T_k = [k + (n - 1)]\tau$$

k cycles until
1st instruction
completes

1 cycle for
each of the rest
(n-1) instructions

Pipeline Speedup ⁽¹⁾

n instructions, k stages

n instructions, k stages
 τ = stage delay = cycle time

Time
not pipelined: $T_1 = nk\tau$

(pessimistic because of
assuming that each stage
would still have τ cycle time)

Time
pipelined: $T_k = [k + (n - 1)]\tau$

Speedup
with
k stages: $S_k = \frac{T_1}{T_k} = \frac{nk\tau}{[k + (n - 1)]\tau} = \frac{nk}{[k + (n - 1)]}$

Fig. 12.14 (Fig. 11.14 [Stal99])

Branch Problem Solutions (5)

- Delayed Branch
 - compiler places some useful instructions (1 or more!) after branch (or jump) instructions
 - these instructions are almost completely executed when branch decision is known
 - execute them always!
 - hopefully useful work
 - o/w NO-OP
 - less actual work lost
 - can be difficult to do

Fig. 13.7

(Fig. 12.7 [Stal99])

Branch Probl. Solutions (contd) (6)

- Multiple instruction streams
 - execute speculatively in both directions
 - Problem: we do not know the branch target address early!
 - if one direction splits, continue each way again
 - lots of hardware
 - speculative results (registers!), control
 - speculative instructions may delay real work
 - bus & register contention?
 - Need multiple ALUs?
 - need to be able to cancel not-taken instruction streams in pipeline

Branch Probl. Solutions (contd) (2)

- Prefetch Branch Target IBM 360/91 (1967)
 - prefetch just branch target instruction
 - do not execute it, I.e., do only FI stage
 - if branch take, no need to wait for memory
- Loop Buffer
 - keep n most recently fetched instructions in high speed buffer inside CPU
 - works for small loops (at most n instructions)

Branch Probl. Solutions (contd) (4)

- Static Branch Prediction
 - guess (intelligently) which way branch will go
 - static prediction: all *taken* or all *not taken*
 - static prediction based on opcode
 - E.g., because BLE instruction is *usually* at the end of loop, guess “taken” for all BLE instructions

Branch Probl. Solutions (contd) (5)

- Dynamic branch prediction
 - based on previous time this instruction was executed
 - need a CPU “cache” of addresses of branch instructions, and taken/not taken information
 - 1 bit
 - end of loop always wrong twice!
 - extension: prediction based on two previous time executions of that branch instruction
 - need more space (2 bits)

Fig. 12.17

(Fig. 11.16 [Stal99])

Branch Address Prediction (3)

- It is not enough to know whether branch is taken or not
- Must know also branch address to fetch target instruction
- Branch History Table
 - state information to guess whether branch will be taken or not
 - previous branch target address
 - stored in CPU “cache” for each branch

Branch History Table

PowerPC 620

- Cached
 - entries only for most recent branches
 - Branch instruction address, or tag bits for it
 - Branch taken prediction bits (2?)
 - Target address (from previous time) or complete target instruction?
- Why cached
 - expensive hardware, not enough space for all possible branches
 - at lookup time check first whether entry for correct branch instruction
 - Index/tag bits of branch instruction address

CPU Example: PowerPC

- User Visible Registers Fig. 12.23 (Fig. 11.22 [Stal99])
 - 32 general purpose regs, each 64 bits
 - Exception reg (XER), 32 bits Fig. 12.24a (Fig. 11.23a)
 - 32 FP regs, each 64 bits
 - FP status & control (FPSCR), 32 bits Table 12.3 (Tbl. 11.3)
 - branch processing unit registers
 - Condition, 32 bits Fig. 12.24b (Fig. 11.23b)
 - 8 fields, each 4 bits
 - identity given in instructions Table 12.4 (Tbl. 11.4)
 - Link reg, 64 bits
 - E.g., return address
 - Count regs, 64 bits
 - E.g., loop counter

CPU Example: PowerPC

- Interrupts
 - cause
 - system condition or event
 - instruction

Table 12.5

(Fig. 11.5 [Stal99])

CPU Example: PowerPC

(Tbl. 11.6 [Stal99])

Table 12.6

- Machine State Register, 64 bits
 - bit 48: external (I/O) interrupts enabled?
 - bit 49: privileged state or not
 - bits 52&55: which FP interrupts enabled?
 - bit 59: data address translation on/off
 - bit 63: big/little endian mode
- Save/Restore Regs SRR0 and SRR1
 - temporary data needed for interrupt handling

Power PC Interrupt Invocation

(Tbl. 11.6 [Stal99])

Table 12.6

- Save return PC to SRR0
 - current or next instruction at the time of interrupt
- Copy relevant areas of MSR to SRR1
- Copy additional interrupt info to SRR1
- Copy fixed new value into MSR
 - different for each interrupt
 - address translation off, disable interrupts
- Copy interrupt handler entry point to PC
 - two possible handlers, selection based on bit 57 of original MSR

Power PC Interrupt Return

(Tbl. 11.6 [Stal99])

Table 12.6

- Return From Interrupt (rfi) instruction
 - privileged
- Rebuild original MSR from SRR1
- Copy return address from SRR0 to PC

-- End of Chapter 12: CPU Structure --

5 stage pipelined version of datapath

(Fig. 6.12)

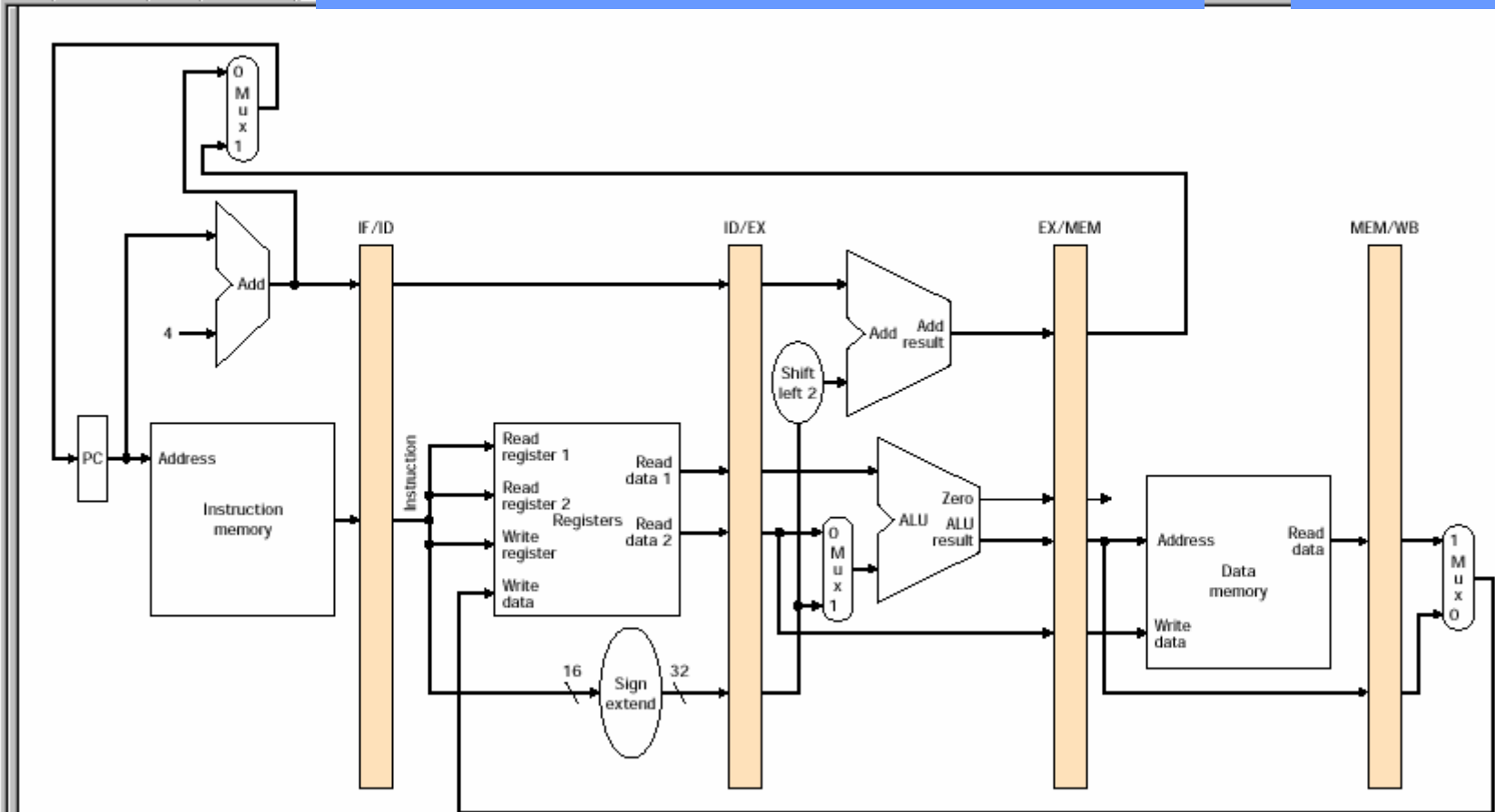

(Patterson-Hennessy, Computer Org & Design, 2nd Ed, 1998)