

# IA-64, P4 HT and Crusoe Architectures Ch 15

IA-64 General Organization  
Predication, Speculation  
Software Pipelining  
Example: Itanium  
Pentium 4 HT  
Crusoe General Architecture  
Emulated Precise Exceptions

16.10.2003

Copyright Teemu Kerola 2003

1

## General Organization

- EPIC - Explicit Parallel Instruction Computing
  - parallelism visible at instruction level, not "secretly" implement in processor
    - new instruction stream semantics
  - compiler prevents many "hazards" (dependency problems), hardware can depend on it
- VLIW (Very Long Instruction Word)
- Branch predication – many speculative execution tracks
- Speculate on memory data loads

Fig 15.1

16.10.2003

Copyright Teemu Kerola 2003

2

# IA-64 General Organization

- 128 64-bit (+ Not a Thing bit) registers
  - integer, logical, general purpose
- 128 82-bit registers
  - floating point (IEEE double extended)
  - graphics
- 64 1-bit predicate registers
- 8 64-bit branch registers

f0:	0.0
f1:	1.0

Fig 15.1

Slide 9 [Lamb00]

# Instruction Format

- Instruction (41 bits)
  - operation & predicates
  - up to 6 instruction executions in parallel
- Instruction bundle (128 bits)
  - three instructions & template
  - smallest unit to fetch instructions from memory
- Instruction group
  - machine instructions that could be issued in parallel
  - end of group marked with ”;” in symbolic assembly language code

Slide 8 [Lamb00]

Fig 15.2

Tbl 15.3

# Predicated Execution

- Execute each branch Fig 15.3 (a)
  - if-then-else gives two predicates, and each path will advance with its own predicate
- Predicate values known only after branch instruction completes
- Discard "wrong" path, commit "right" path
  - known always before commit time? Slide 18 [Lamb00]

# Speculative Loading, I.e., Control Speculation

- Start loading from memory in advance so that data is available earlier
  - load instruction "hoisted" earlier in code, before some branch instruction
  - interrupts are delayed (via NaT bit in register), and handled only at the time when they would have been handled normally

```
je L2  
ld8 r1 = [r5]
```



```
ld8.s r1 = [r5]  
je L2  
chk.s r1, recovery
```

Fig 15.3 (b)

Slides 27, 28  
[Lamb00]

# Data Speculation

Slide 26 [Lamb00]

- Start loading from memory in advance so that data is available earlier
  - load instruction "hoisted" earlier in code, before a store instruction that might alter just that memory location
  - Advanced Load Address Table (ALAT, special hardware) keeps track of data speculation addresses
  - each store will clear target address in ALAT (if any)
  - at original load instruction time, a new load is initiated if ALAT entry was cleared

Slide 31 [Lamb00]

alias  
problem:

```
je L1  
st8 [r3] = r13  
ld8 r1 = [r5]
```



```
ld8.a r1 = [r5]  
je L1  
st8 [r3] = r13  
ld8.c r1 = [r5]
```

Slides 29-30  
[Lamb00]

16.10.2003

Copyright Teemu Kerola 2003

7

# IA-64 Register Set

Fig 15.7

- 128 general purpose regs (stacked, rotated)
- 128 floating point regs (rotated)
- 64 predicate regs
- 8 branch regs
- instruction pointer (bundle address)

Tbl 15.5

Slides 15-17 [Lamb00]

16.10.2003

Copyright Teemu Kerola 2003

8

# Software Pipelining

- Unwrap loops in hardware, so that multiple iterations are done in parallel code p. 559
  - code is not unrolled, but action is code p. 560
  - each iteration done with different registers (automatic register renaming) Slide 25 [Lamb00]
  - beginning and end of loop handled as special cases (with predicates)
  - each iteration execution is spread enough to make room for ILP Fig 15.6
  - loop branches are replaced with special loop terminating instructions that control sw pipelining
  - why is this called software pipelining?

# Itanium

Slide 40 [Lamb00]

- 1<sup>st</sup> implementation of IA-64 architecture
- "Simpler" than conventional superscalar
  - no reservation stations, reorder buffers
  - no large renamed register set for architecture registers
  - no dependency issue logic
  - dependencies solved by compiler, and explicitly solved in code
- Very large memory address space
  - explicit control over memory hierarchies
  - explicit memory op fences

Slides 10-12 [Lamb00]

# Itanium

- Powerful cache hierarchy
  - split L1: 16KB + 16KB, 4-way set assoc, 32B lines
  - unified L2: 96KB, 6-way set assoc, 64B lines
  - off-chip unified L3: 4MB, 4-way set assoc
- TLB hierarchy
  - instruction TLB: 64 entry full assoc
  - data L1 TLB: 32 entry direct assoc
  - data L2 TLB: 96 entry full assoc
  - Hardware Page Walker – use mem hierarchy to locate address mapping
- 10-stage in-order pipeline

Slide 42 [Lamb00]

Slides 43-44 [Lamb00]

## Itanium 2

- Upgraded cache hierarchy
  - split L1: 16KB + 16KB, 4-way set assoc, **64B** lines
  - unified L2: **256KB**, **8-way** set assoc, **128B** lines
  - **on-chip** unified L3: **3MB**, **12-way** set assoc
- TLB hierarchy
  - instruction **L1 TLB**: 32 entry full assoc
  - instruction **L2 TLB**: 128 entry full assoc
  - data L1 TLB: 32 entry **full** assoc
  - data L2 TLB: **128** entry full assoc

## Itanium 2

- Max 6 issues per cycle
  - 11 issue ports
- Many functional units, all fully pipelined
  - 6 general purpose ALU's
  - 4 data cache memory ports
  - 6 multimedia FU's
  - 4 FPU's
  - 3 branch units
- Perfect loop prediction
- Lots of branch prediction hints in code

# IA-64 Summary

- Parallel semantics for ISA (Instr Set Arch)
- Lots of explicit ILP (Instr Level Parallelism)
- Memory hierarchy (cache) controls in ISA
- Memory synchronization primitives in ISA
  - normal access temporal locality hint (E.g., ifetch.t1) suggests to keep data in L1D, L2, and L3
  - less important hint (E.g., Fpload.nt1) suggests to keep data only in L2 and L3.

# IA-64 Summary (contd)

- Lots of speculative work, that may be wasted
  - predicated execution
  - miss-prediction costs mostly avoided
  - branch prediction hints in ISA
  - load speculation: "hoist" loads above branch or store
- Large visible register set – no hidden rename regs
  - automatic stack frame save/restore
- HW-controlled software pipelining



## Pentium 4 HT

- HT – Hyper-threading
- 2 logical processors in one physical processor
- OS sees it as symmetric 2-processor system
- Use wait cycles to run the other thread
  - memory accesses (cache miss)
  - dependencies, branch miss-predictions
- Utilize usually idle int-unit, when float unit in use
- 3.06 GHz + 24%(?)
  - GHz numbers alone are not so important
- 20 stage pipeline
- Fall 2003: CS dept new PCs with P4 HT processor

# Execution Pipeline

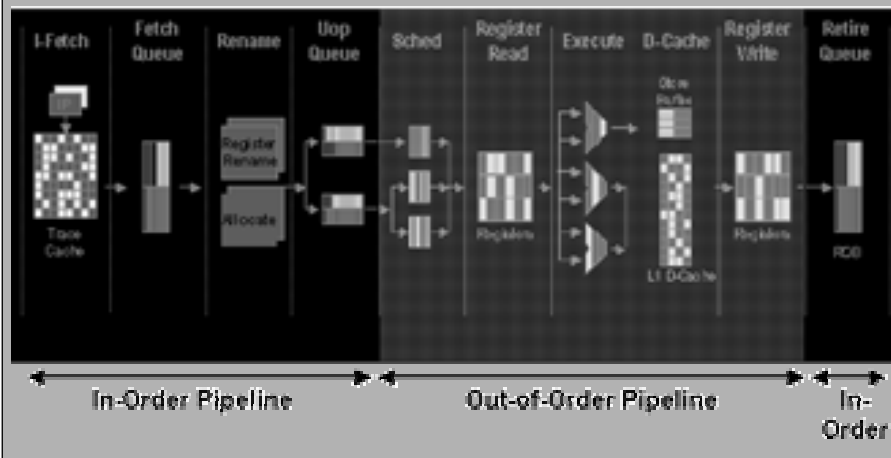

16.10.2003

Copyright Teemu Kerola 2003

19

16.10.2003

Copyright Teemu Kerola 2003

20

# Crusoe Architecture

Major Ideas  
General Architecture  
Emulated Precise Exceptions  
What to do with It

## Background

- Transmeta Corporation
  - Paul Allen (Microsoft), George Soros (Soros Funds)
  - David R. Ditzel (Sun) Orig. CEO, now CTO
  - Edmund J. Kelly, Malcolm John Wing, Robert F. Cmelik
  - Linus B. Torvalds, February 1997 → 2003
- Patent 5832205
  - applied August 20, 1996
  - granted November 3, 1998
  - many (a few) other patents ...
- Crusoe processor
  - published January 19, 2000

## Basic Idea(s) <sup>(5)</sup>

faster

cheaper

- Create a new processor which, when coupled with “morph host” emulator, can run Intel/Windows code faster than state-of-the-art Intel processor, *or* with same speed but with less electric power
- New processor can be implemented with significantly fewer gates than competitive processors
- Compete with Intel, friendly with Microsoft
  - sell chip with emulator code to system manufacturers (Dell, IBM, Sun, etc etc)
- X86 (IA-32) binary is new binary standard
- Native OS not so important
  - services from target OS: E.g., Windows or Linux

16.10.2003

Copyright Teemu Kerola 2003

23

## Major General Ideas

- Emulation can be faster than direct execution
- TLB used to solve new problems
  - track memory accesses for memory mapped I/O
  - track memory accesses for self-modifying code
- Most of executed code generated “on-the fly”
  - not compiled before execution begins
  - extremely optimized dynamic code generation
- Optimized code allows for simpler machine
  - smaller, faster, uses less power?

16.10.2003

Copyright Teemu Kerola 2003

24

## Major General Ideas (contd)

- Self-modified code (dynamically created code) can be generated so that it is extremely optimized for execution
  - issue dependencies, reorder, reschedule problems solved at code generation (not in HW)
  - processor HW does not need to solve these
- Optimize for speed, but only when needed
  - do not optimize for speed when exact state change is required (this is the tricky part!)
- Alias detection to assist keeping global variables in registers

## Major General Ideas (contd)

- NOT: faster and with less power

Class action suit (5.7.2001) ... stating that ... a revolutionary process that delivered longer battery life in Mobile Internet Computers while delivering high performance ....

Settled 13.3.2003 for 5.5 million dollars

<http://www.lieffcabraser.com/transmeta.htm>

## Major Emulation Ideas

- Target processor (I.e., Intel processor) state kept in dedicated HW registers
  - working state (“speculated” state?), committed state
- Memory store buffer keeps uncommitted (“speculated”) emulated memory state
- Specific instructions support emulation
  - commit, rollback (exact exceptions)
  - prot (aliases)
- TLB (and VM) designed to support emulation
  - A/N-bit (mem-mapped I/O), T-bit (self-mod. code)

## General Architecture

- VLIW implementation
  - VLIW = Very Long Instruction Word
  - 4 simultaneous RISC instructions in ”molecule”
    - one each of float, int, load/store, branch
  - large L3 Translation Cache for VLIW ”molecules”
    - 8-16 MB
    - similar to Pentium 4 Trace Cache?
  - no circuitry for issue dependencies, reorder, optimize, reschedule
    - compiler takes care of these
    - data & structural dependencies under compiler control?

## General Architecture (contd)

- Large register set
  - native regs: 64 INT, 32 FP
    - extra regs for renaming
  - target architecture regs: complete CPU state
    - INT, FP, control Reax, Recx, Rseq, Reip
    - working regs for normal emulation
    - committed regs for saving emulated processor state

## General Architecture (contd)

- TLB
  - new features to solve new problems
    - before used to solve also memory protection problems in addition to plain VM address mapping
  - A/N-bit for memory-mapped I/O detection
    - trap to emulator, which creates precise code
    - memory-mapped I/O requires precise emulated processor state changes
  - T-bit for self-modifying code detection
    - trap to emulator, which recreates emulating code in instruction cache (“translation buffer”)

## General Architecture (contd)

- Target memory store buffer
  - implemented with special register(s) to support emulation
  - keep track on which target processor memory stores are committed and which are not
  - uncommitted memory stores can be discarded at rollback
    - modify HW registers implementing it
    - commit & rollback controlled from outside of the processor, not internally as is usual with speculative instructions

## General Architecture (contd)

- RISC instruction set
  - explicitly parallel code (VLIW)
  - *commit* instruction supports emulation
    - commits emulated processor and memory state
    - use when coherent target processor (Intel) state!
  - *rollback* instruction (?) supports emulation
    - some or all of it can be in emulator code
    - recover latest committed emulated target register state
    - delete uncommitted writes from store buffer
    - retranslate emulation code for precise state changes
      - *commit* now after every emulated instruction?
  - *prot* instruction for alias detection



# Ordinary Program Execution

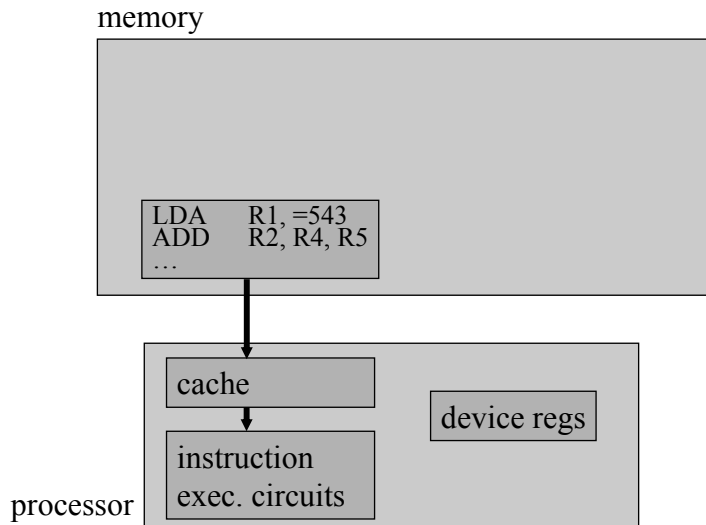

16.10.2003

Copyright Teemu Kerola 2003

33

# Execution of Ordinary Emulator Program

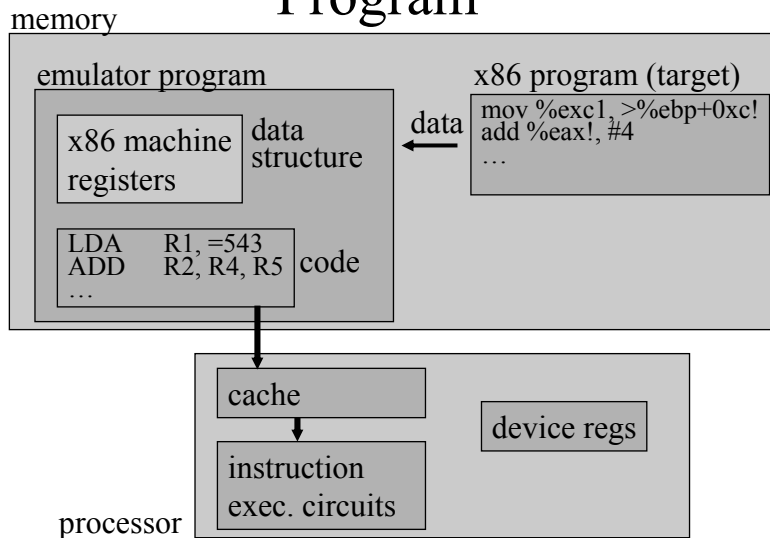

16.10.2003

Copyright Teemu Kerola 2003

34

# Ordinary Emulator

x86-emulator (program)

emulated x86  
mach regs  
as data  
structures

Procedural main program,  
where (in loop forever)  
one gets x86 instructions  
from memory and emulates  
them one at a time with  
proper subroutine

static subroutine  
for each x86  
mach instr

```
LDA    R1, =543
ADD    R2, R4, R5
...
```

# Crusoe Emulator

(emulated x86 mach  
regs in hardware)

Event oriented main program, that  
supervises emulation and generates  
executable machine instructions into cache

Dynamically generated  
(optimized) instruction  
sequences for x86  
instruction sequences

if emulating fast machine instruction  
sequence has not yet been generated,  
translate it and start executing it

if emulated imprecise exception, roll  
back to saved state, generate slow  
but precise emulating (interpreting)  
code, and start executing it

if emulated precise exception, handle  
it and continue with fast code generated  
earlier and still stored code buffer

Load	Add	ftSub	
	Sub	ftMul	brEqu
Store	Add		Jump

# Execution of Crusoe Emulator Program

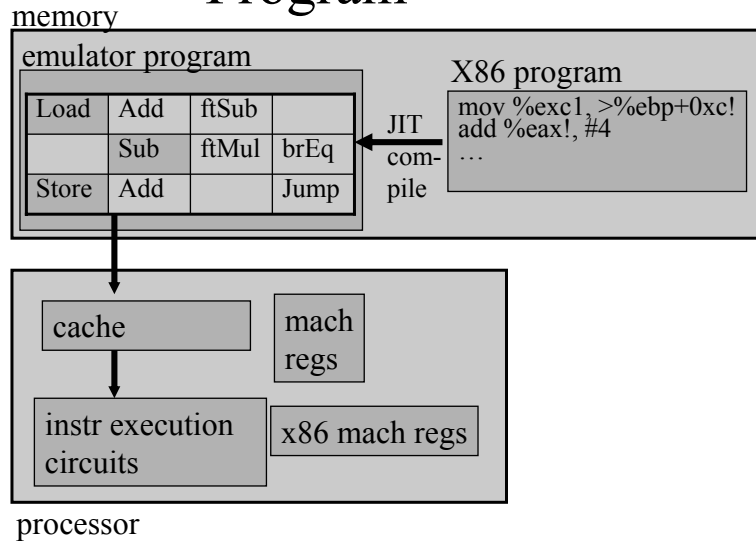

16.10.2003

Copyright Teemu Kerola 2003

37

# Crusoe Logical Structure

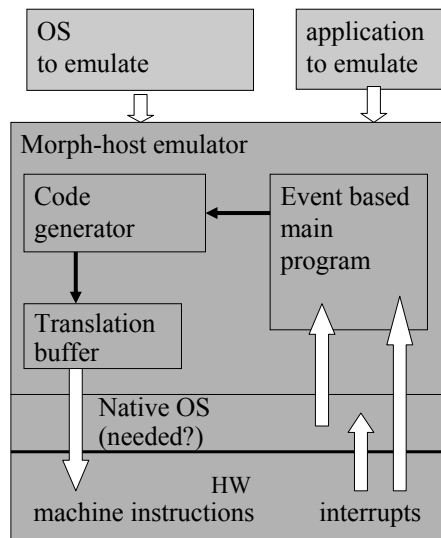

16.10.2003

Copyright Teemu Kerola 2003

38

# Crusoe Physical Structure

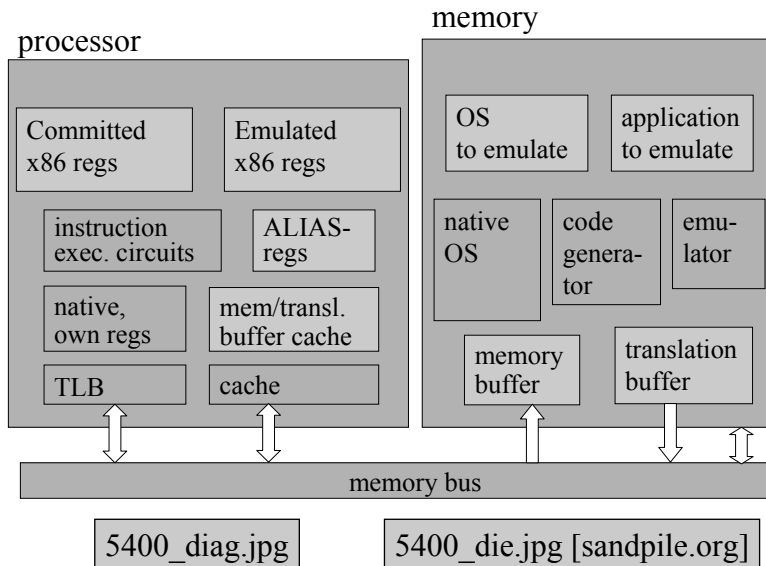

16.10.2003

Copyright Teemu Kerola 2003

39

## Crusoe Summary

- Emulation can be done faster or with less energy than the "real thing"
- VLIW (EPIC?) core architecture
- Special HW to speed up emulation
  - x86 regs
  - memory-mapped I/O detection
  - alias and self-modifying code detection
- Special HW for precise interrupts
  - 2nd set of x86 regs
  - target memory store buffer
  - commit and rollback instruction in ISA

16.10.2003

Copyright Teemu Kerola 2003

40

## Crusoe Summary (contd)

- Complex overall structure
- "Code Morphing Software"
  - JIT optimized code generation
  - compiler and interpreter resident in memory
  - fast but imprecise, or slow and precise emulation
- Optimize for speed or size (power, electricity)?
  - Small size ⇒ cheaper, less power

TM3200, TM5400, ..., TM5600 low power  
TM5800 high speed

## Efficeon processor

- Follow-up for Crusoe
  - published 16.10.2003
  - Same manufacturing technology (.13 micron)
- More parallelism
  - 8 cells per molecule (Crusoe: 4 cells)
  - 256 bit molecule (Crusoe: 128 bits)
- Wait - you get more on the same chip
  - L1 data cache, L1 instr. cache
  - 1 MB L2 unified cache
  - DDR and AGP 4x graphics interface controllers
  - HyperTransport Bus Interface Controller
    - 12x speed as compared to PCI

## -- IA-64 and Crusoe End --



”Aqua 3400 Portable Wireless Internet Access Device, Transmeta 400MHz, 8.4" TFT touch-screen”



”NEC Versa DayLite combines the power-saving 600 Mhz Crusoe TM5600 processor with dual battery systems that NEC claims will extend battery life to up to 7.5 hours on a single charge”